

Semiconductor Diode

Dr Mohammad Abdur Rashid



Readings

Elementary Solid State Physics – M. Ali Omar

Chapter 7: Semiconductors II: Devices

Section: 7.1 – 7.3



Extrinsic semiconductor

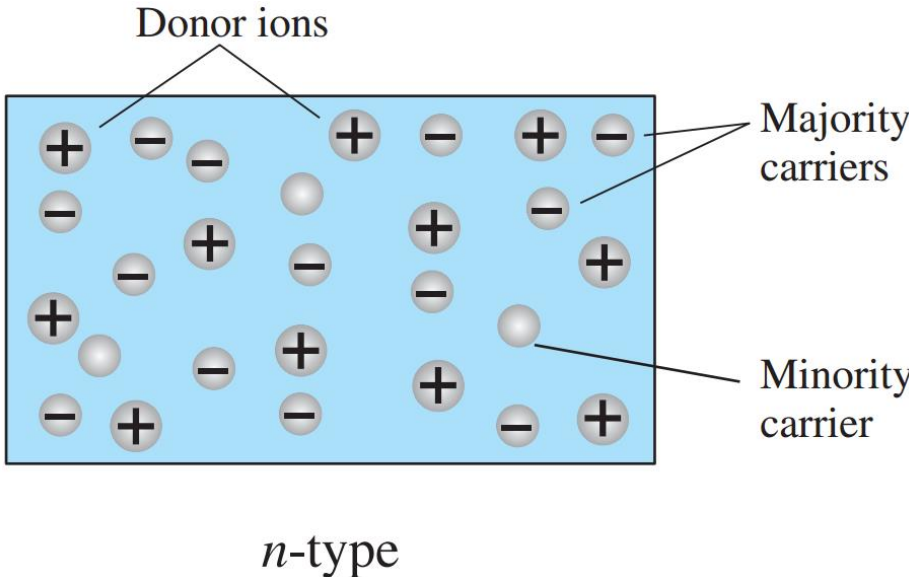
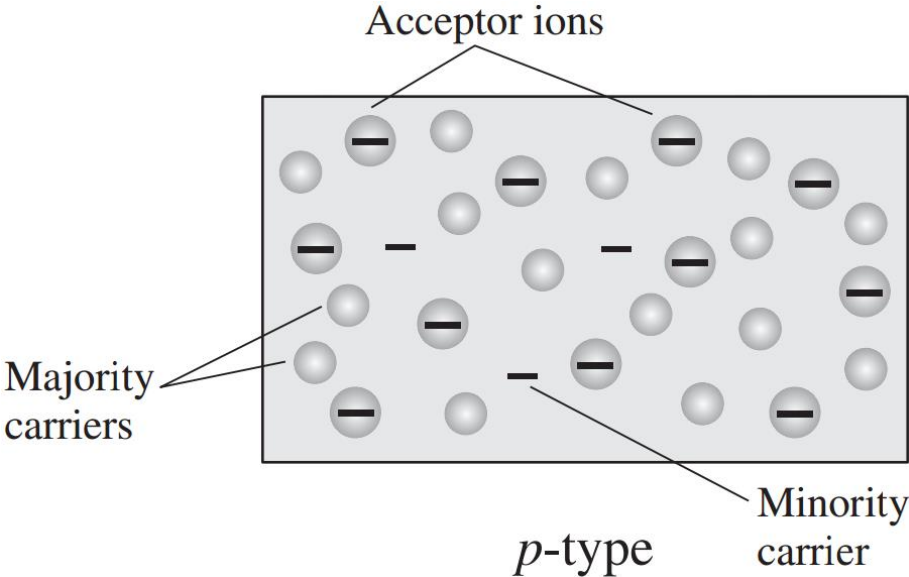

Electronic Devices and Circuit Theory – Boylestad, Nashelsky



p - n junction

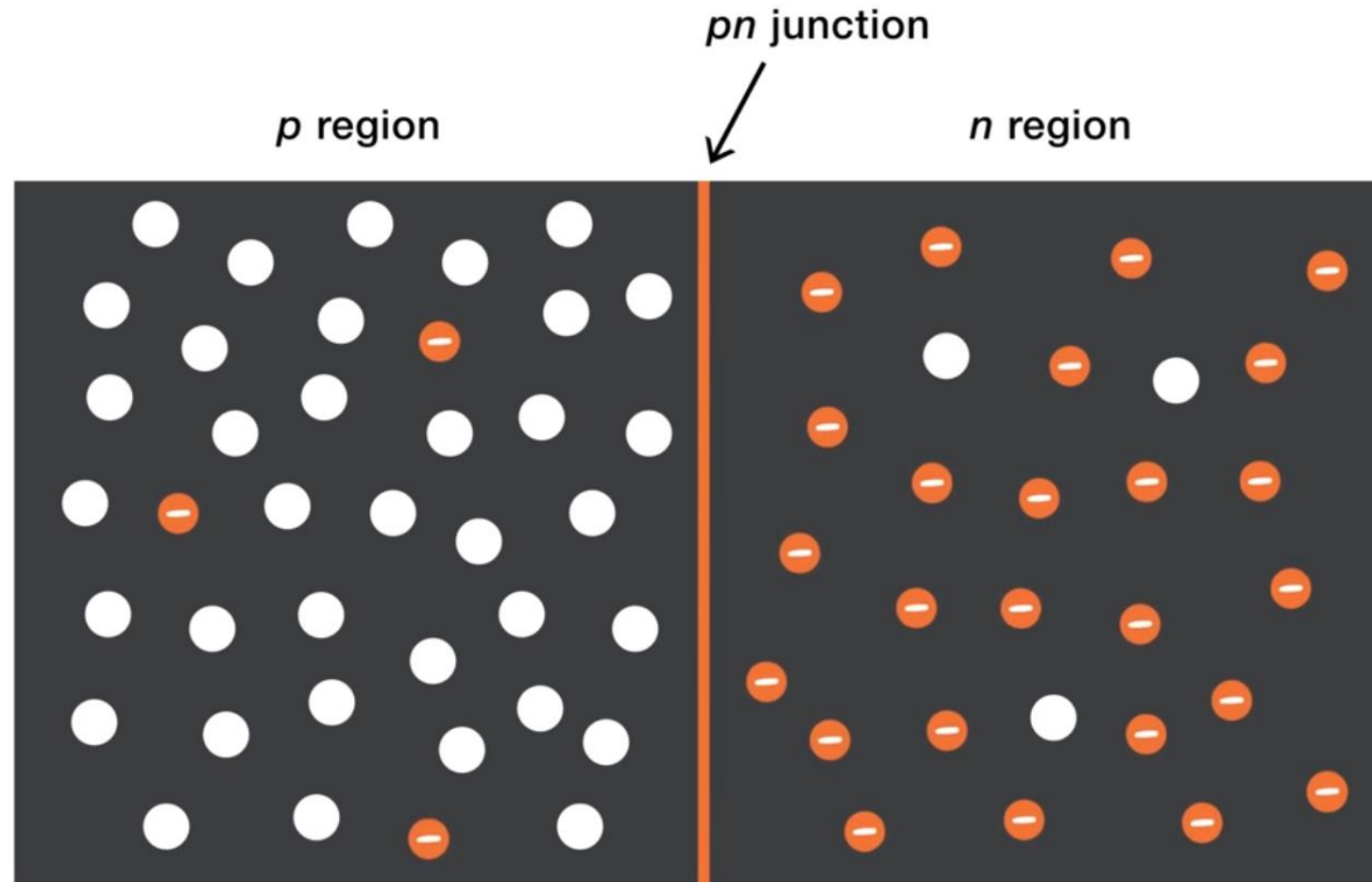

p - n junction

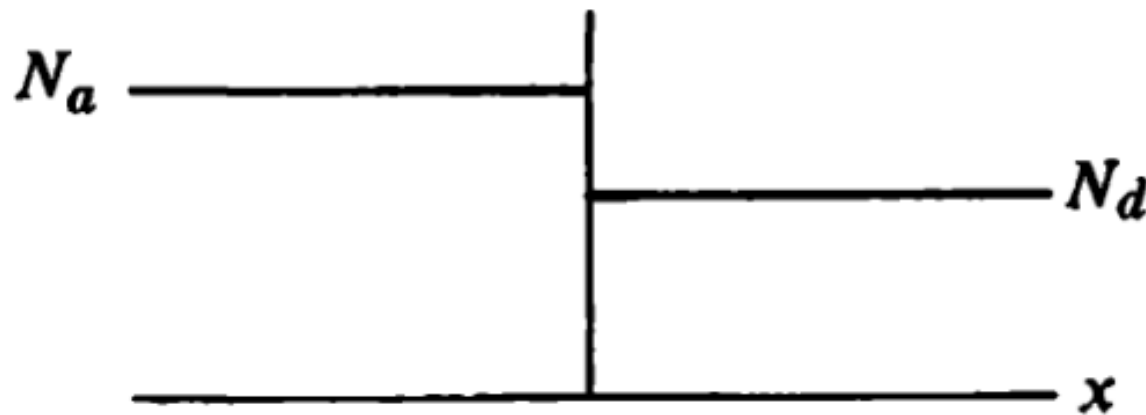
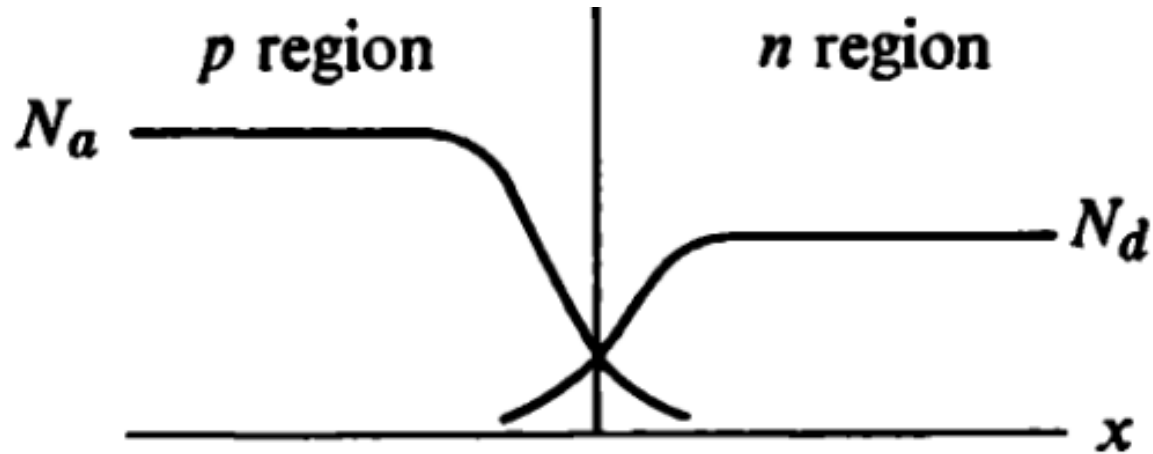

Elementary Solid State
Physics – Ali Omar



p - n junction

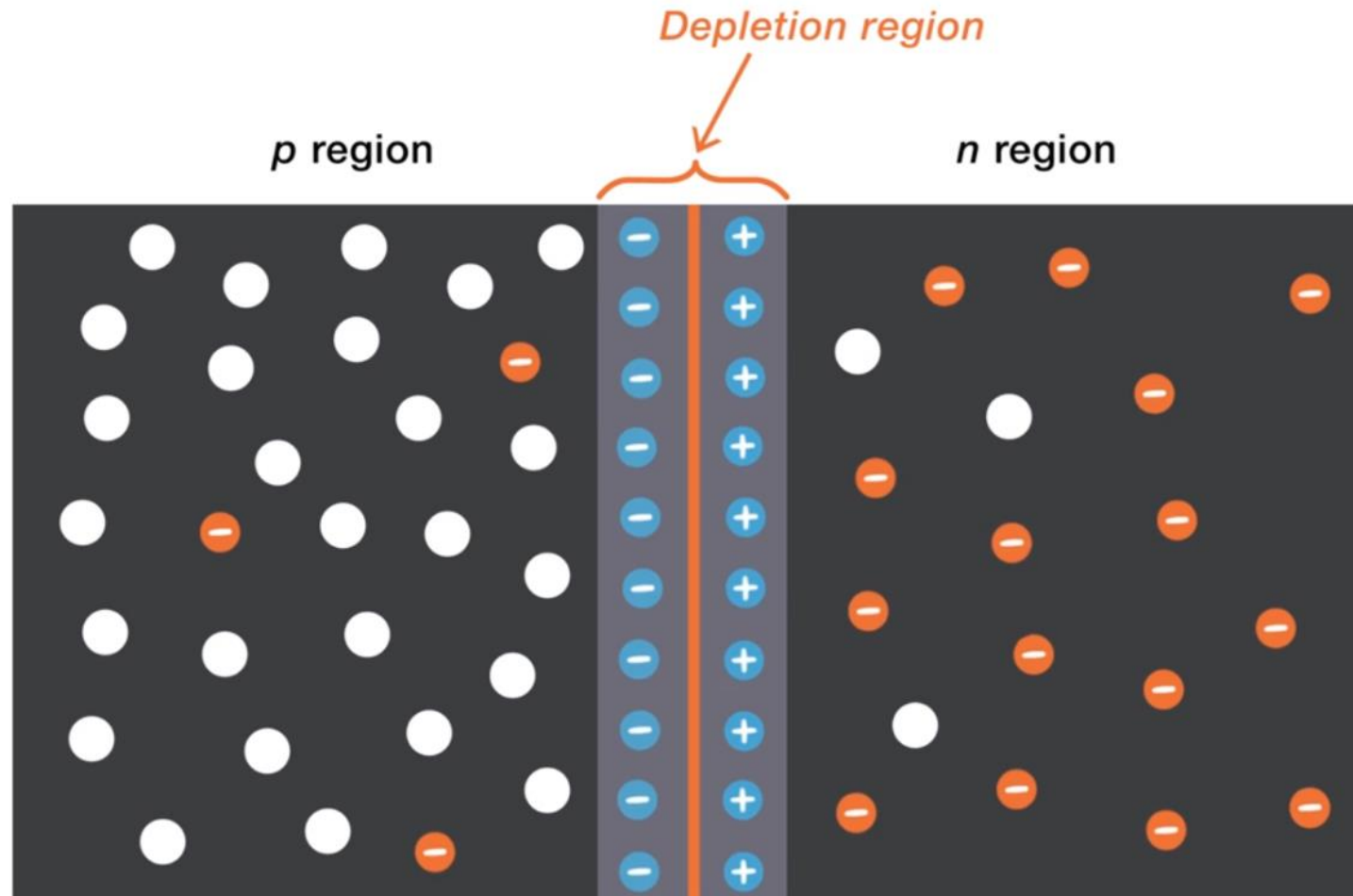

p - n junction

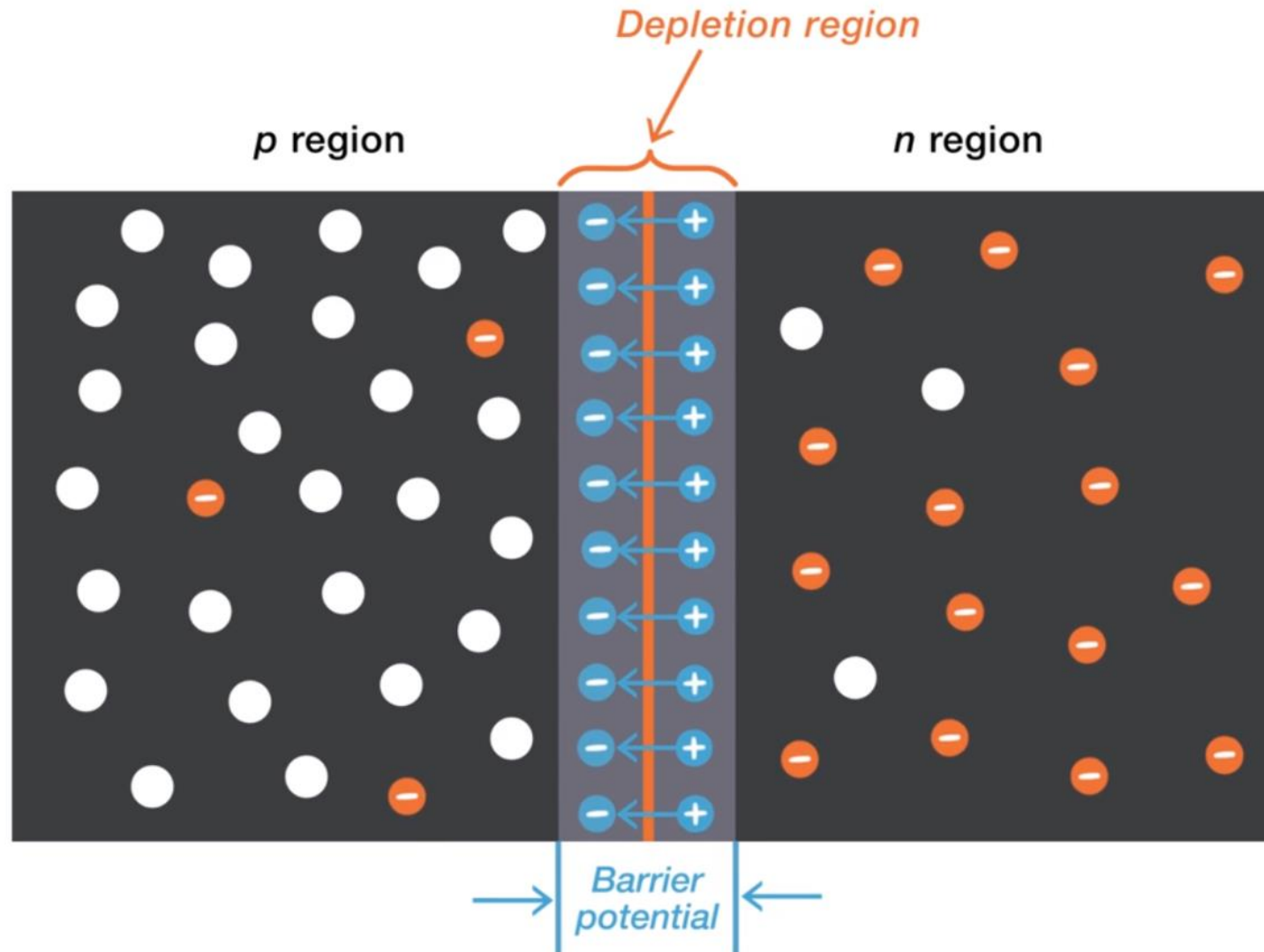

p - n junction

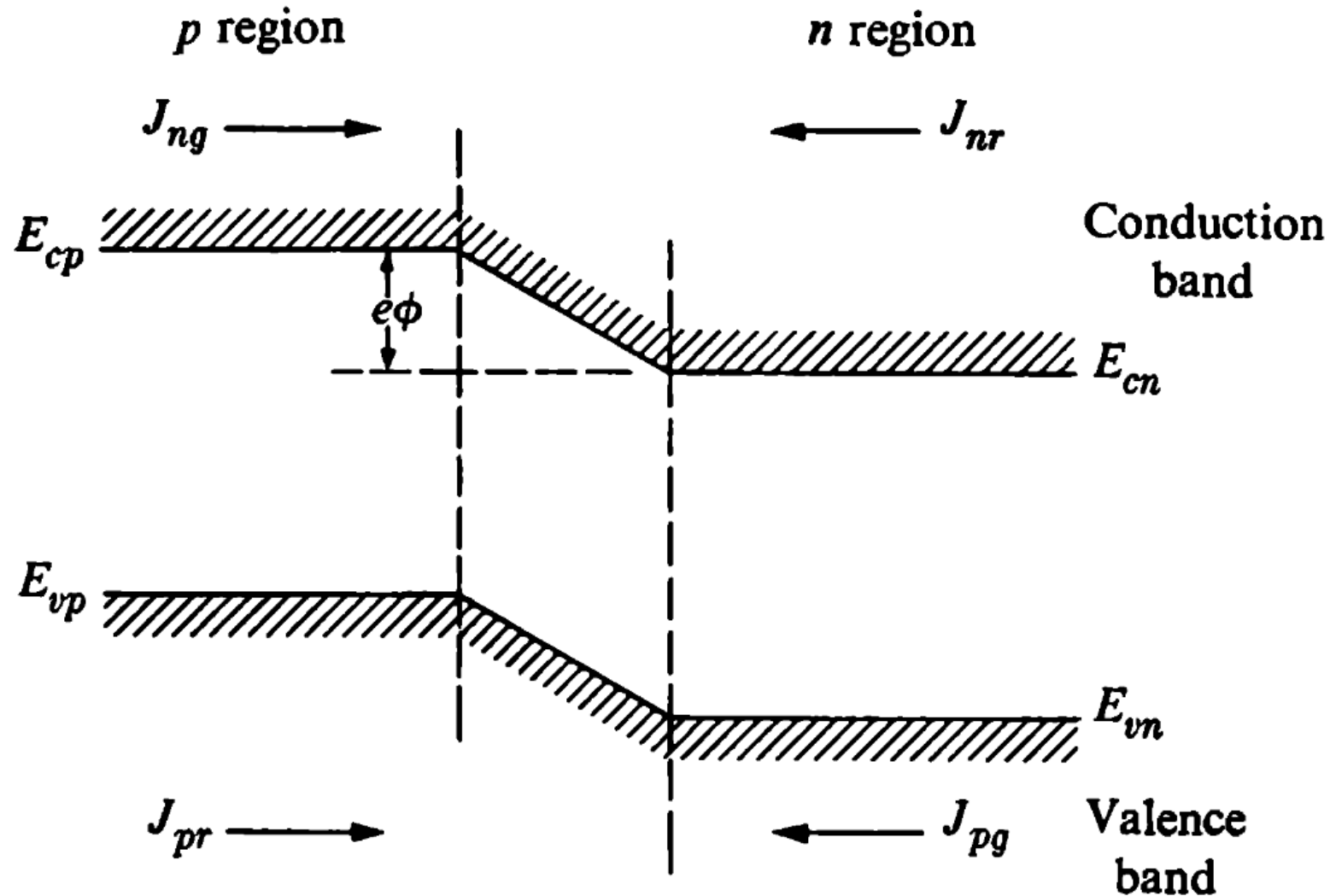

Elementary Solid State
Physics – Ali Omar



p - n junction

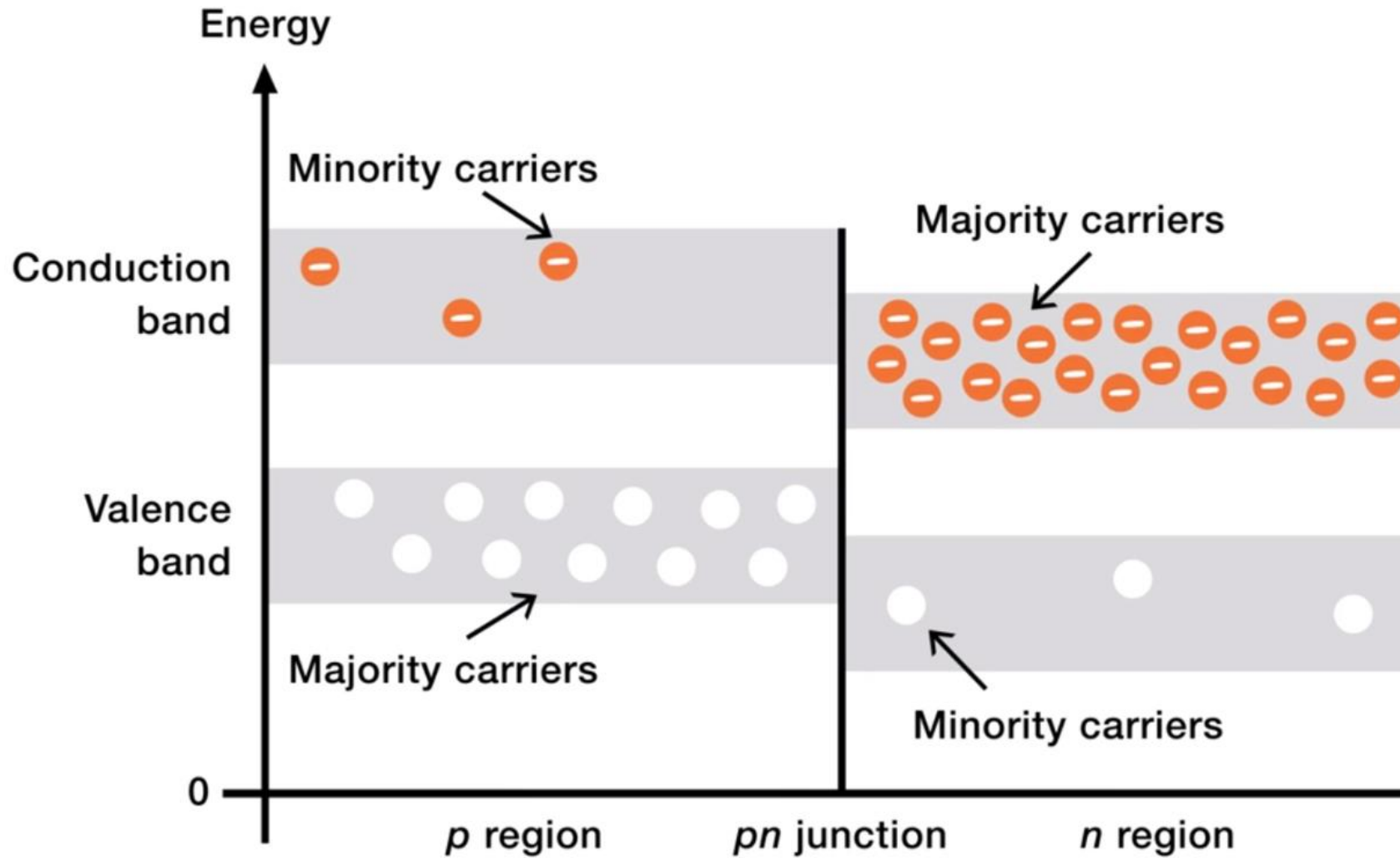

p - n junction

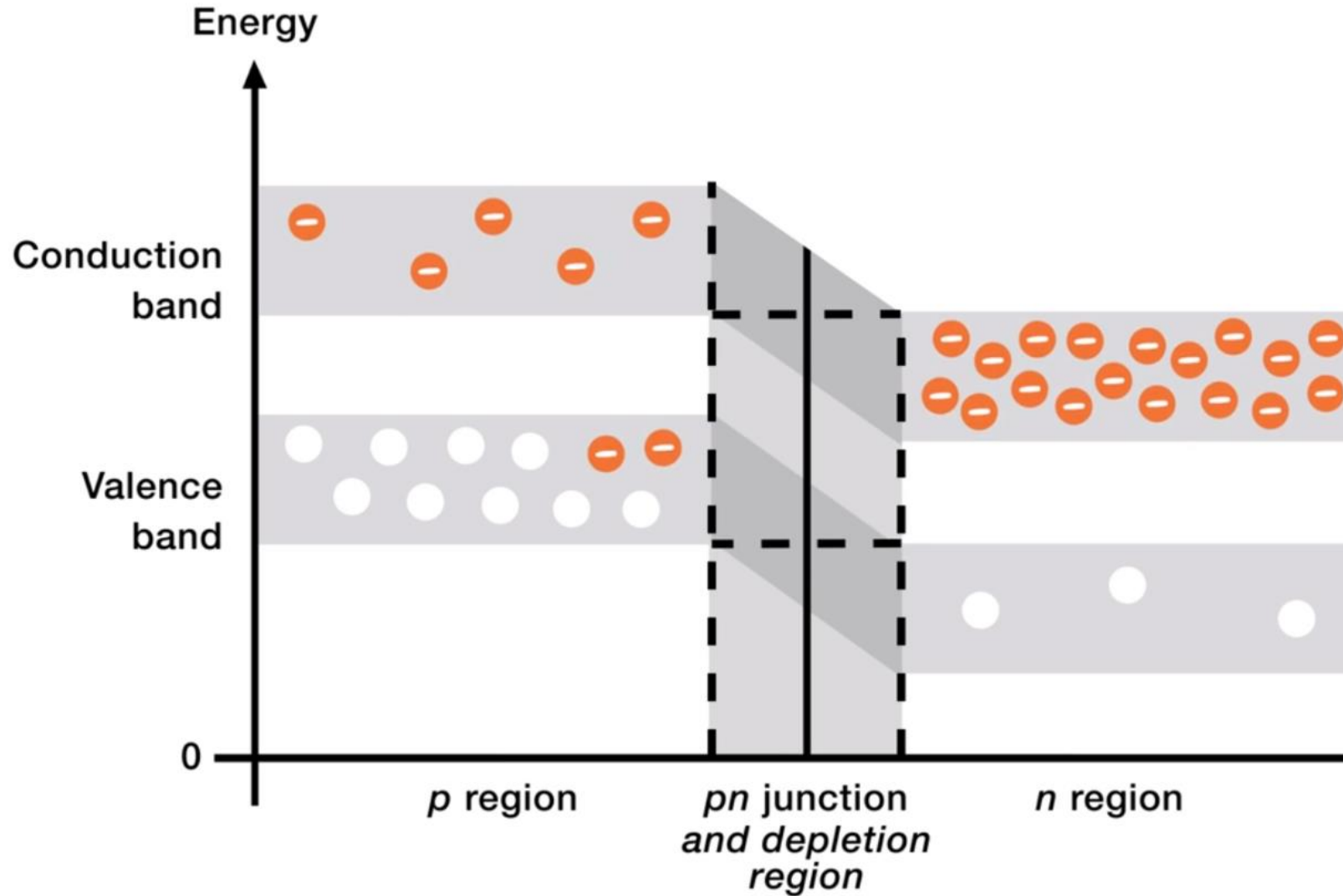

Distribution of charge

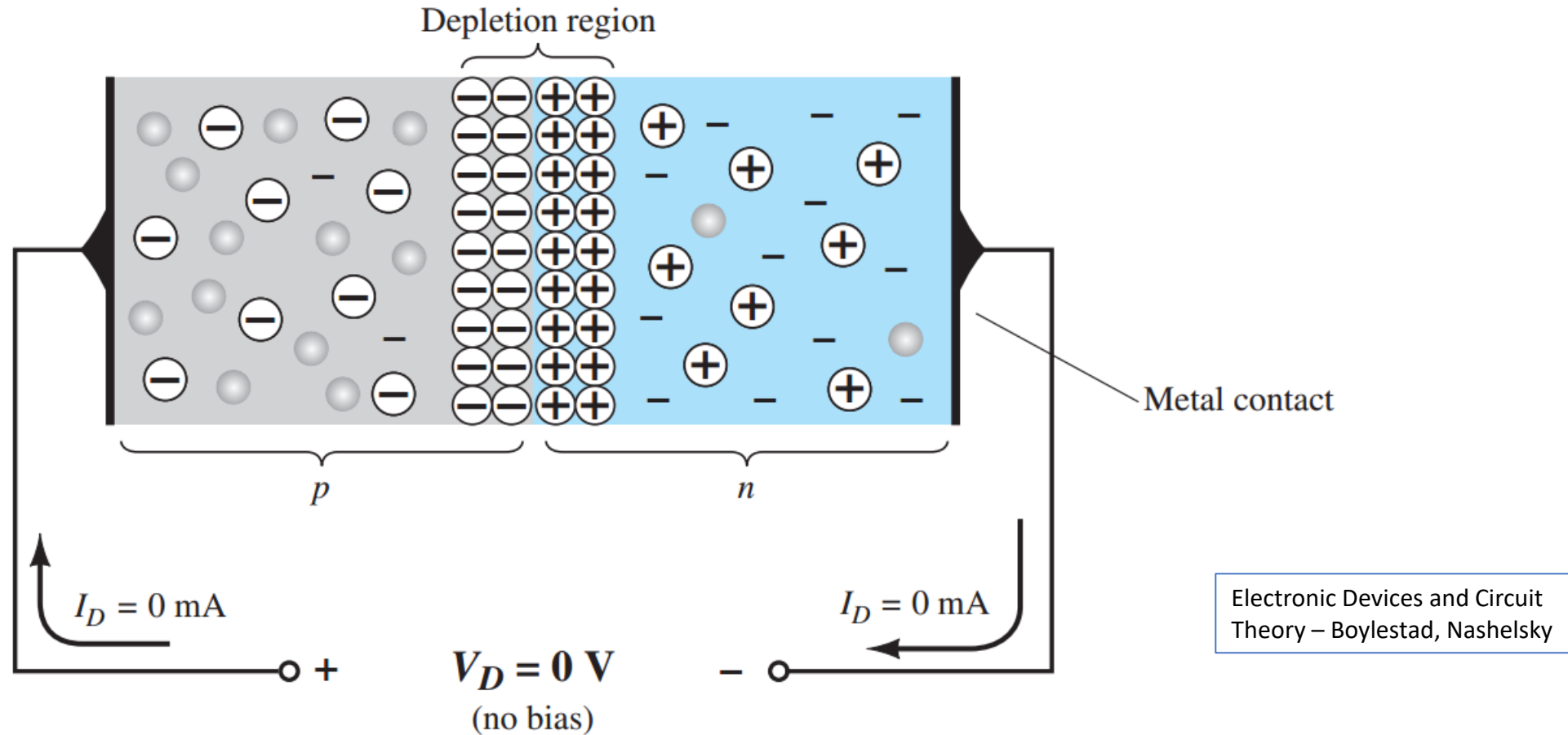

Diode symbol

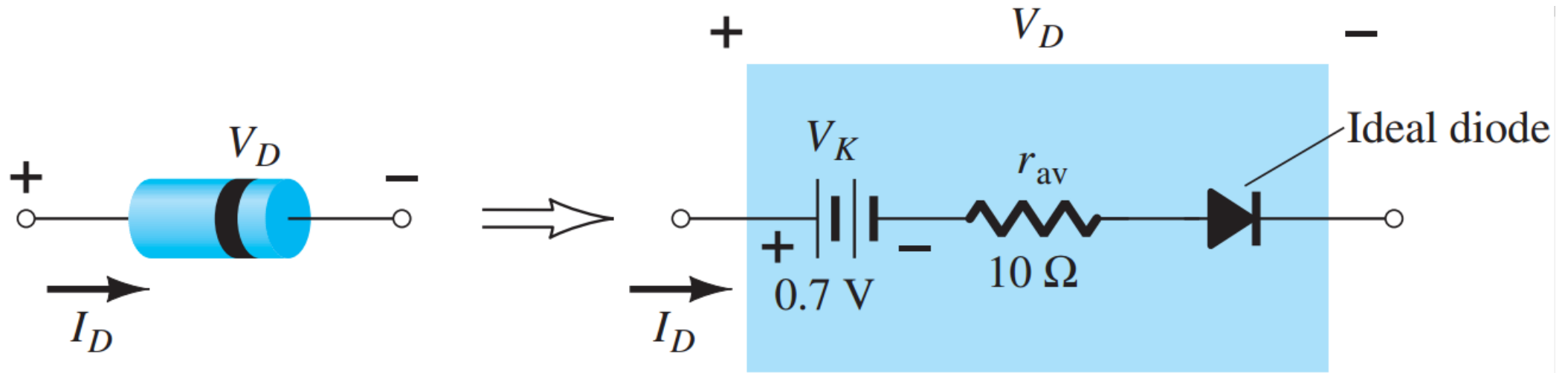

Carrier flow direction

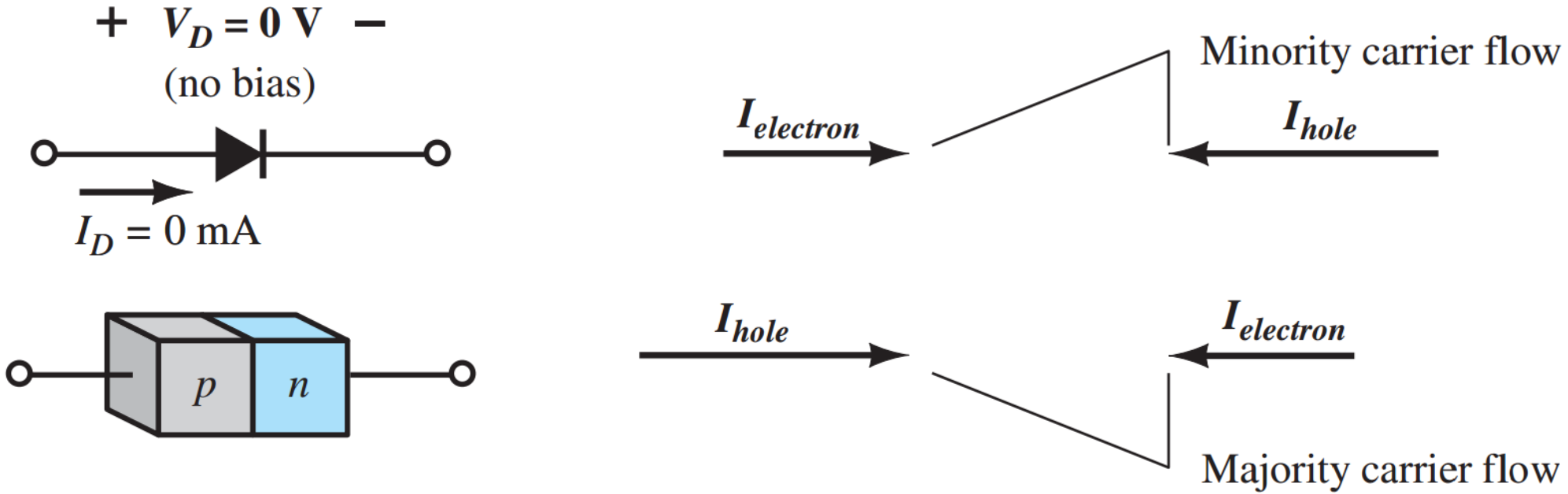

Electronic Devices and Circuit Theory – Boylestad, Nashelsky



Readings

Electronic Devices and Circuit Theory
– Robert L. Boylestad and Louis Nashelsky

Chapter 1: Semiconductor Diodes



No Applied Bias

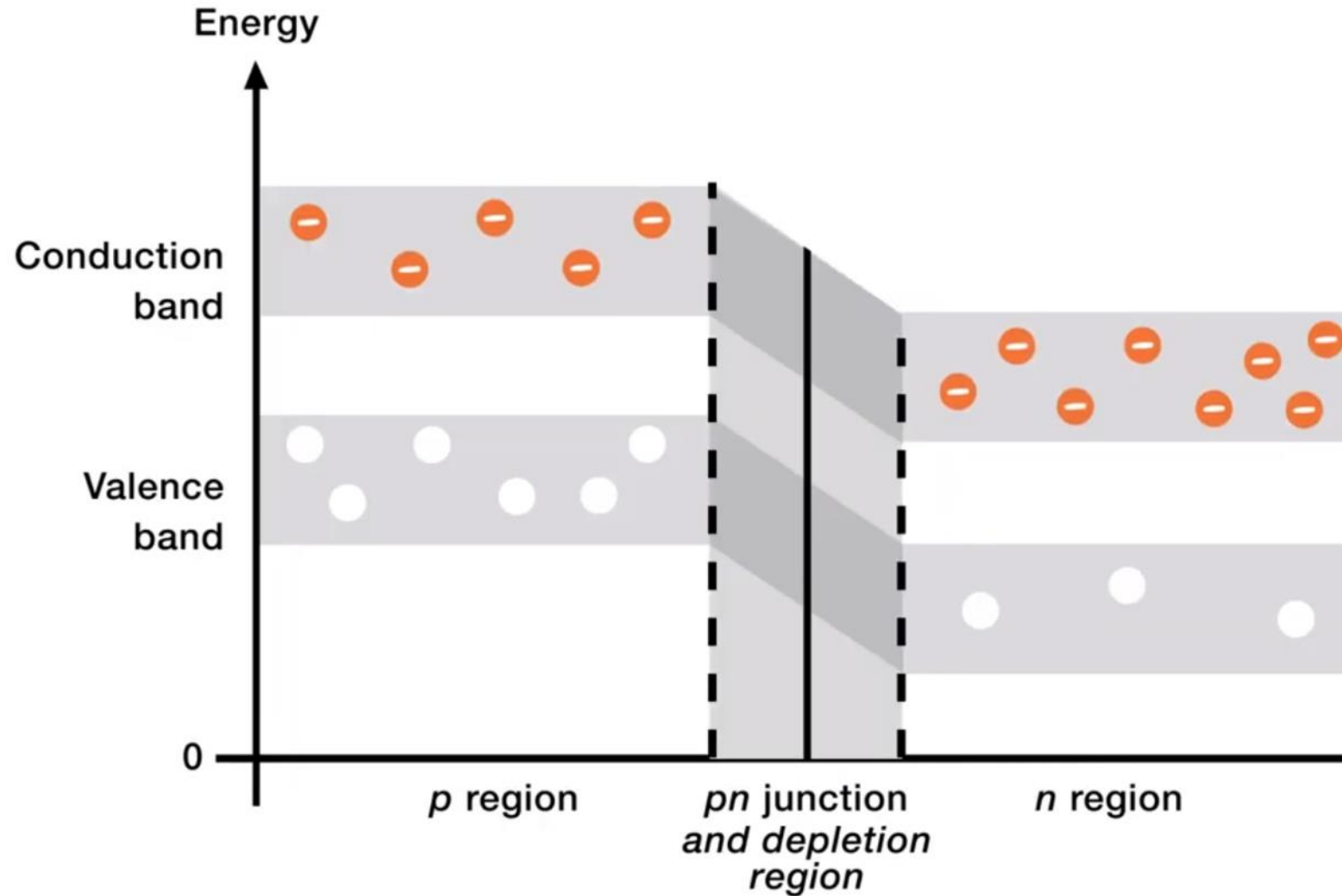

Forward-Bias Condition

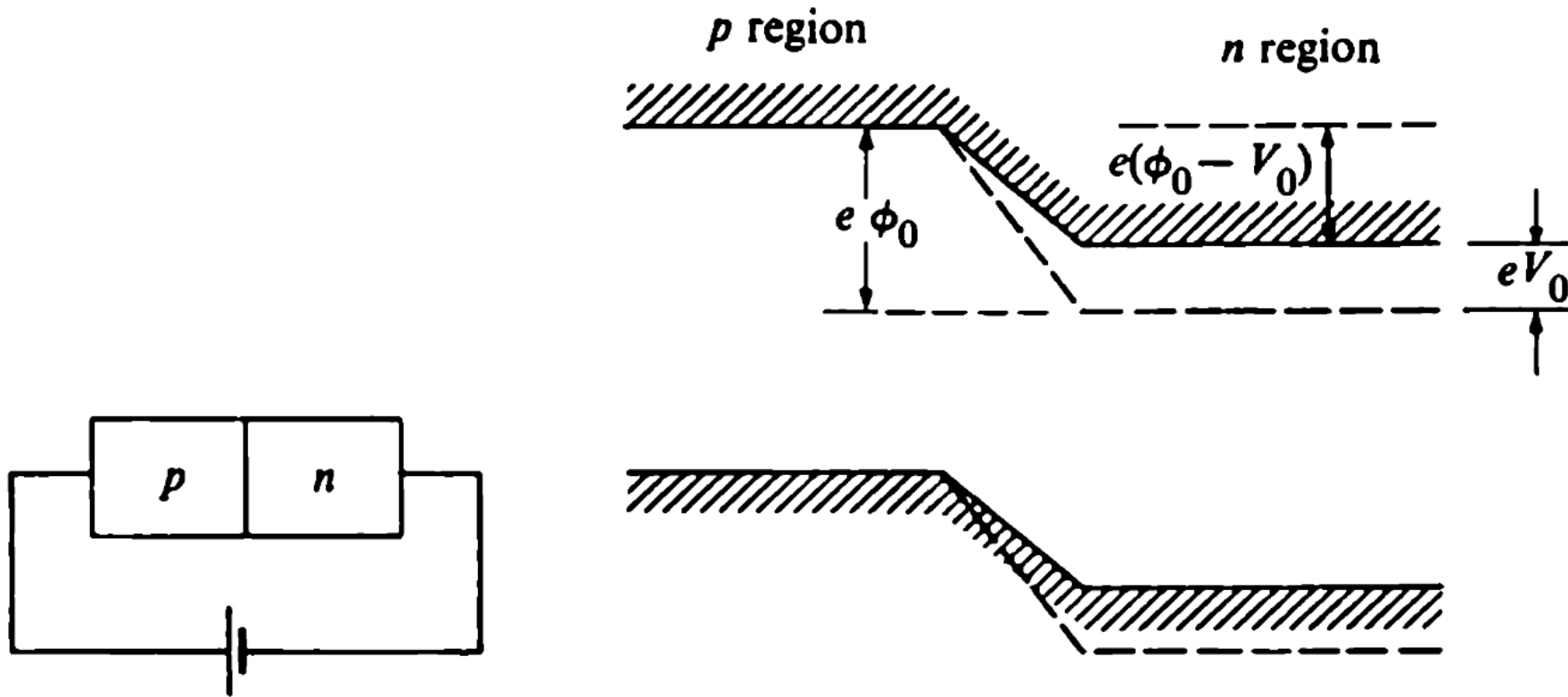

Elementary Solid State Physics – Ali Omar

Forward-Bias Condition

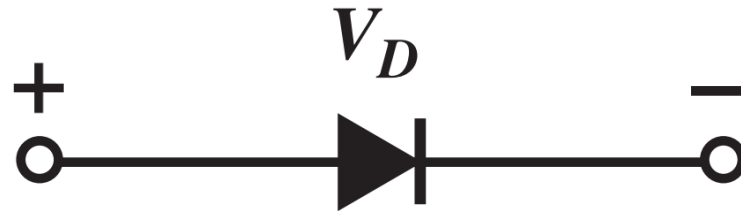
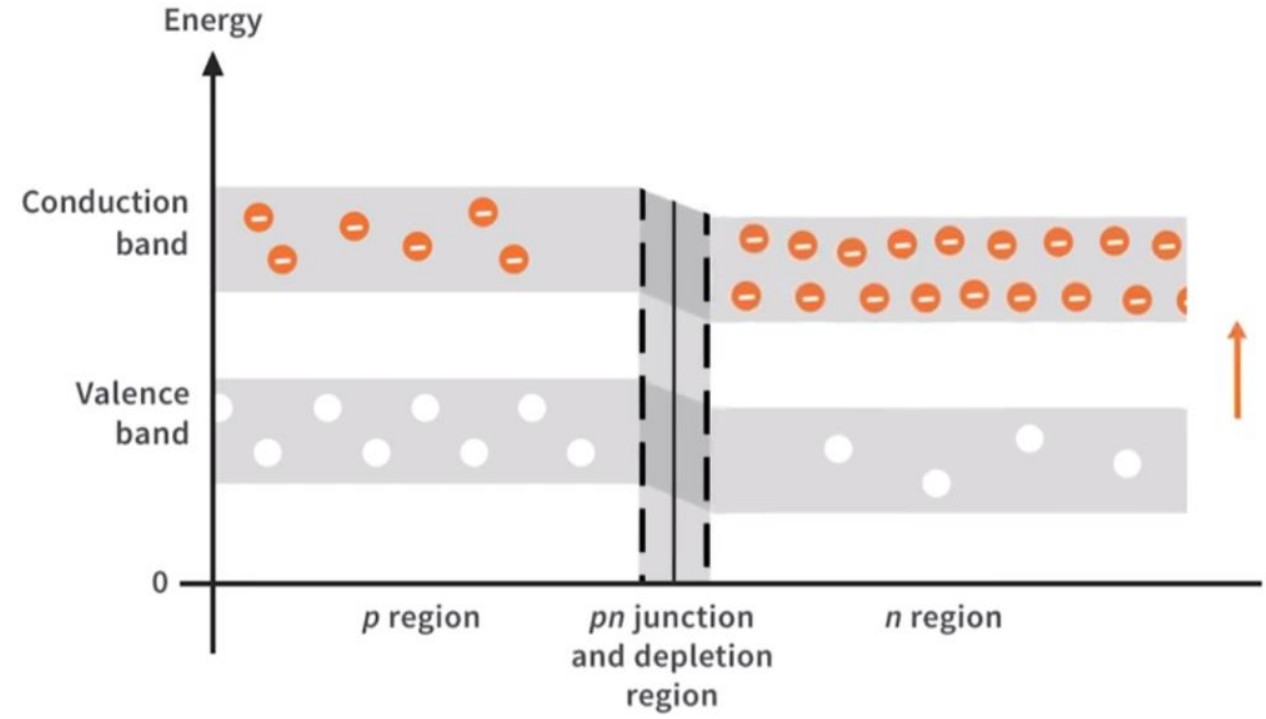
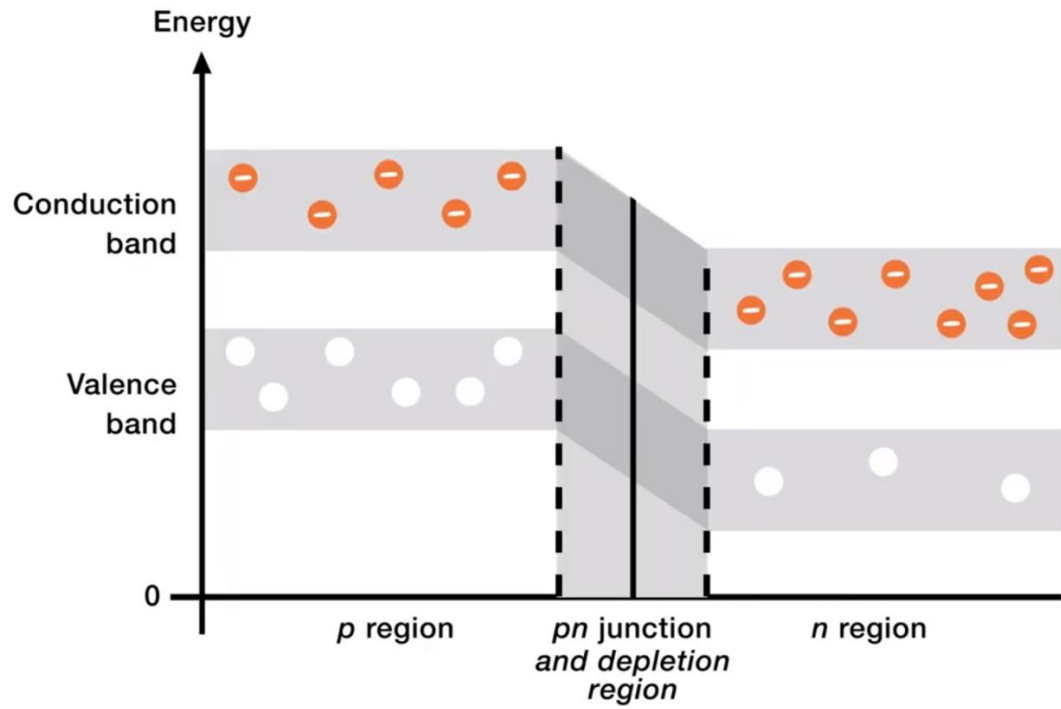

Knee Voltages

Semiconductor	V_K(V)
Ge	0.3
Si	0.7
GaAs	1.2



Forward-Bias Condition

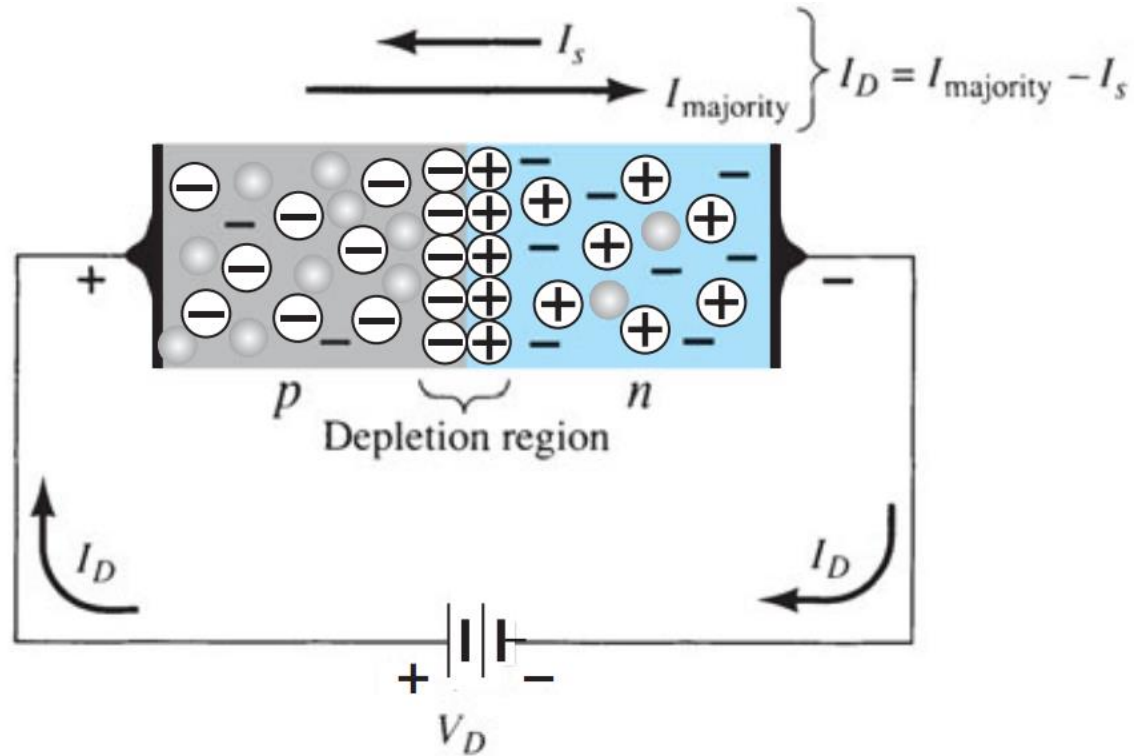

Electronic Devices and Circuit
Theory – Boylestad, Nashelsky



Forward-Bias Condition

It can be demonstrated through the use of solid-state physics that the general characteristics of a semiconductor diode can be defined by the following equation, referred to as Shockley's equation, for the forward- and reverse-bias regions:

$$I_D = I_s(e^{V_D/nV_T} - 1) \quad (\text{A})$$

where I_s is the reverse saturation current

V_D is the applied forward-bias voltage across the diode

n is an ideality factor, which is a function of the operating conditions and physical construction; it has a range between 1 and 2 depending on a wide variety of factors ($n = 1$ will be assumed throughout this text unless otherwise noted).



Forward-Bias Condition

$$I_D = I_s(e^{V_D/nV_T} - 1)$$

The voltage V_T in Eq. (1.1) is called the *thermal voltage* and is determined by

$$V_T = \frac{kT_K}{q} \quad (\text{V})$$

where k is Boltzmann's constant = 1.38×10^{-23} J/K
 T_K is the absolute temperature in kelvins = 273 + the temperature in °C
 q is the magnitude of electronic charge = 1.6×10^{-19} C



Plot of $\exp(x)$

Electronic Devices and Circuit Theory – Boylestad, Nashelsky

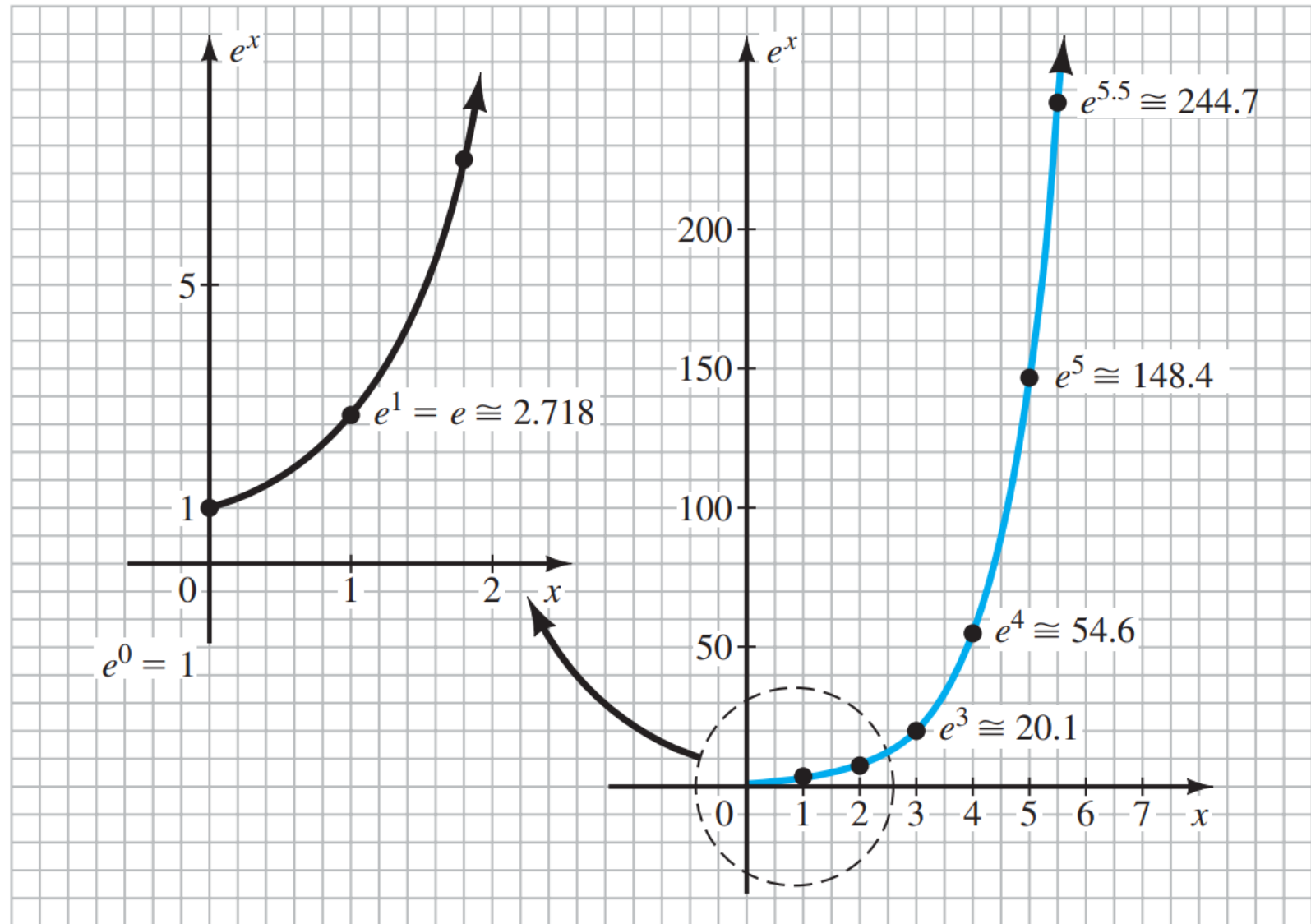

Reverse-Bias Condition

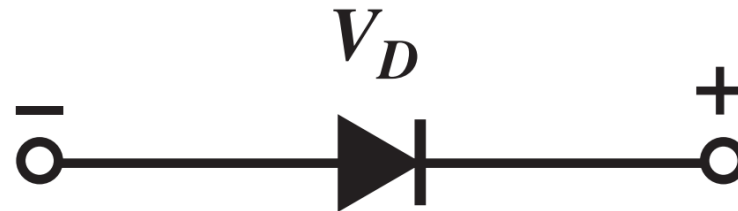
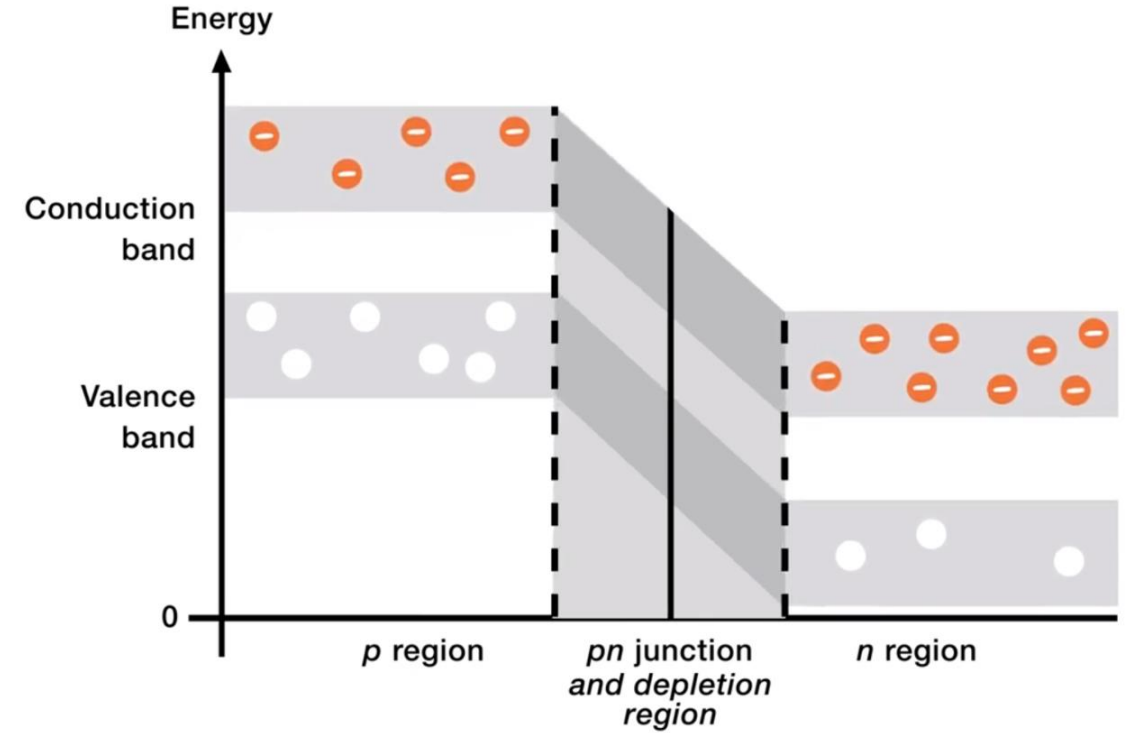
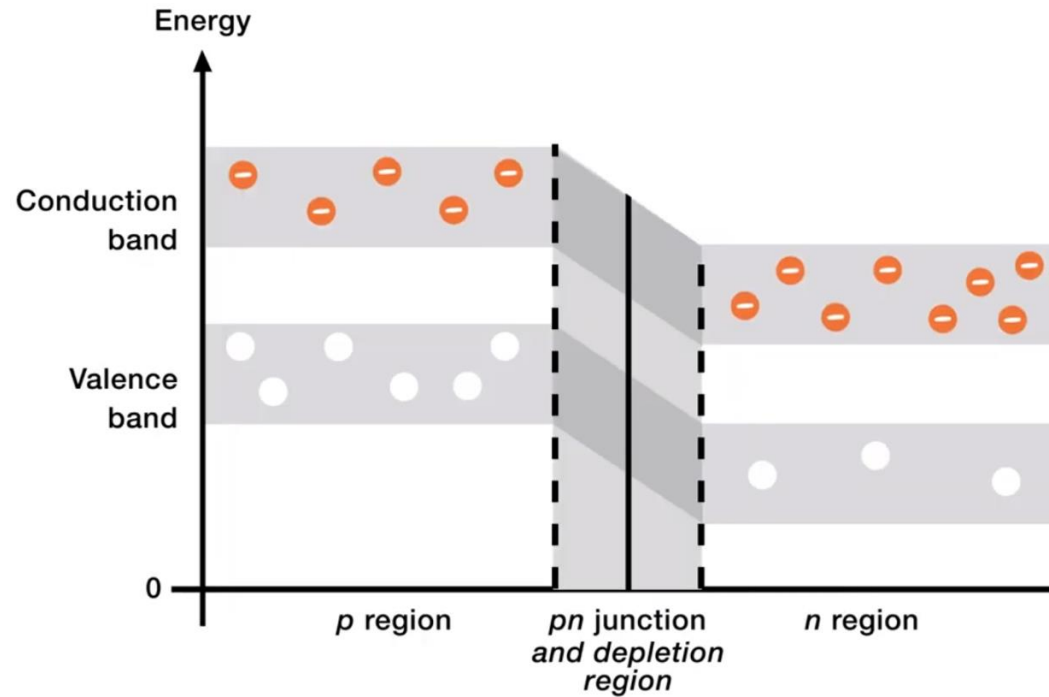

Reverse-Bias Condition

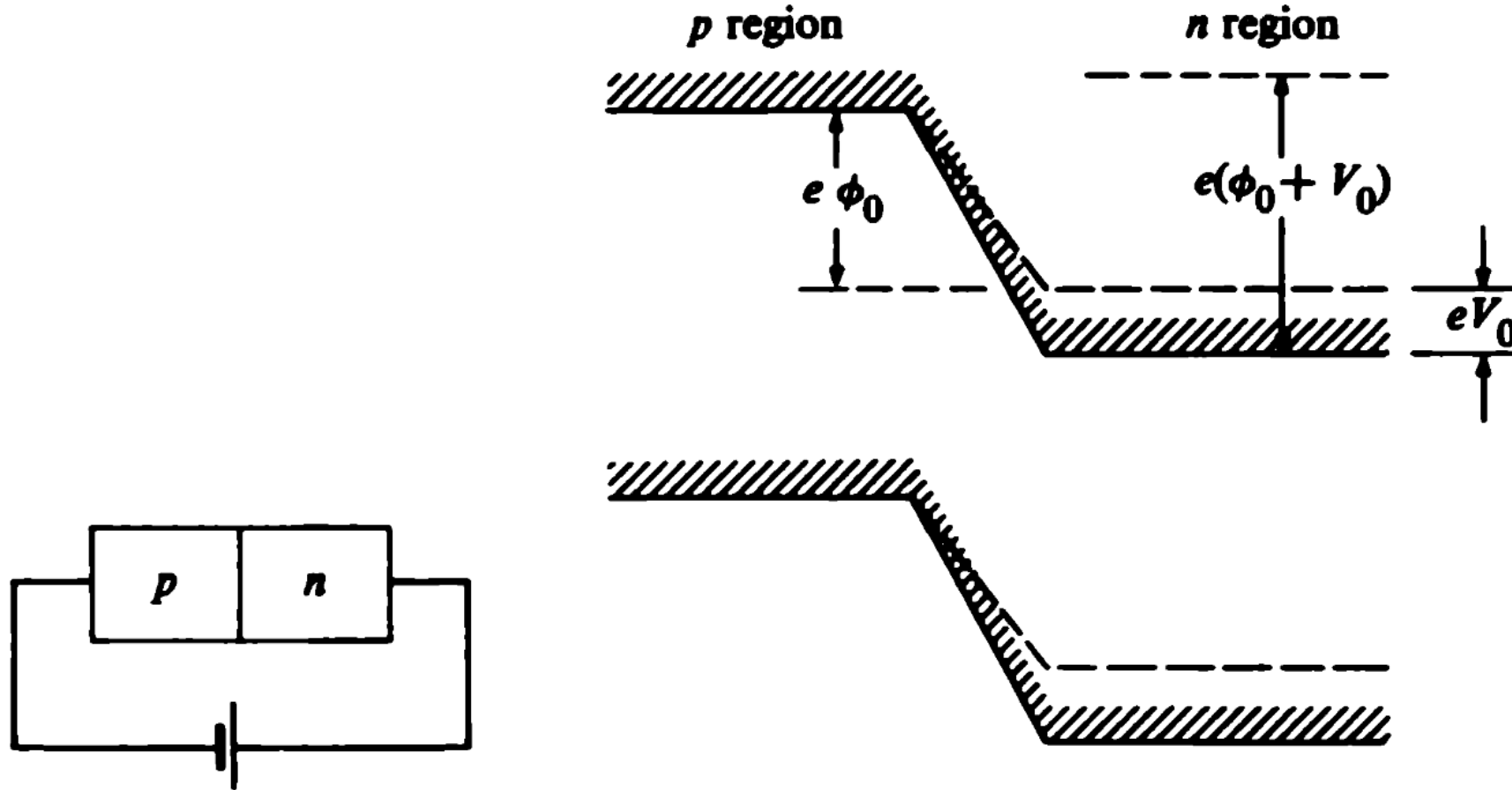

Elementary Solid State Physics – Ali Omar



Reverse-Bias Condition

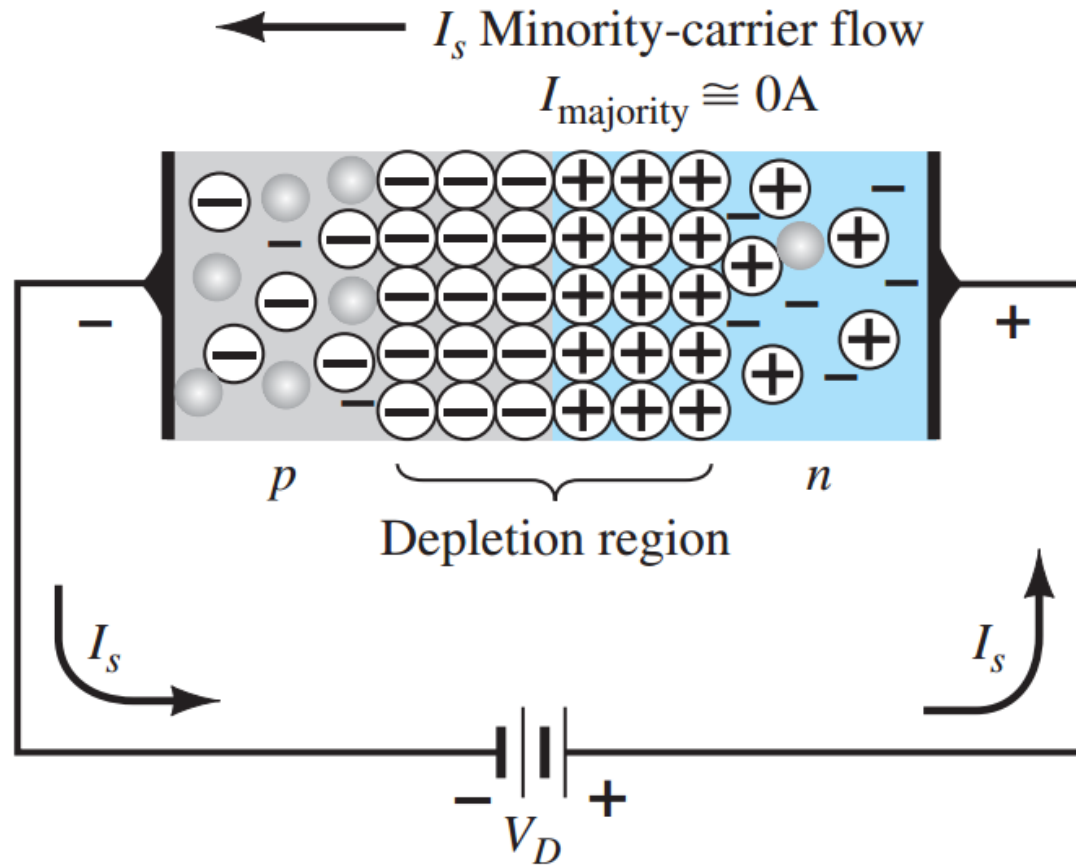

Electronic Devices and Circuit
Theory – Boylestad, Nashelsky



Current versus voltage characteristics

Elementary Solid State
Physics – Ali Omar

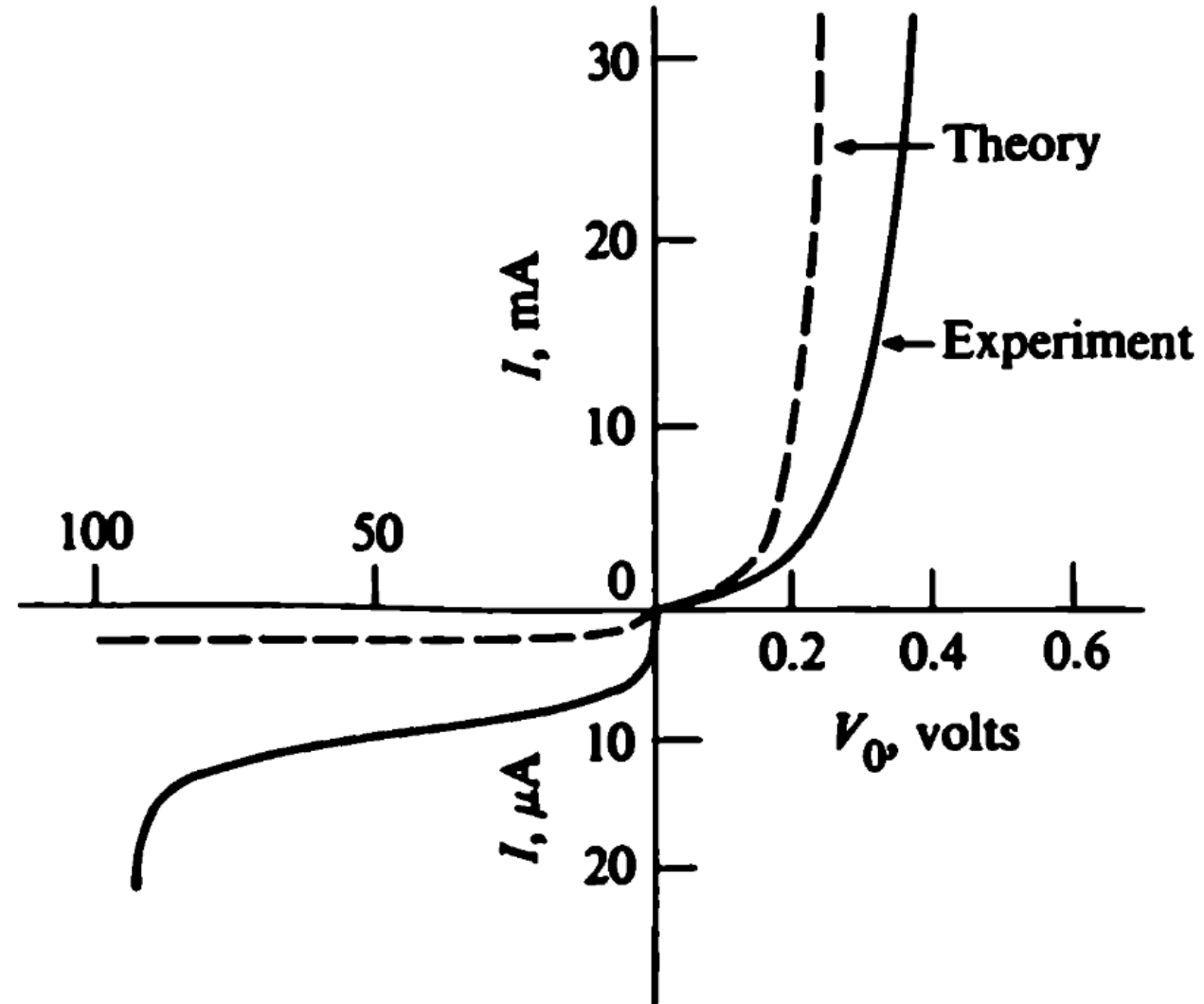

Temperature Effects

Electronic Devices and Circuit Theory – Boylestad, Nashelsky

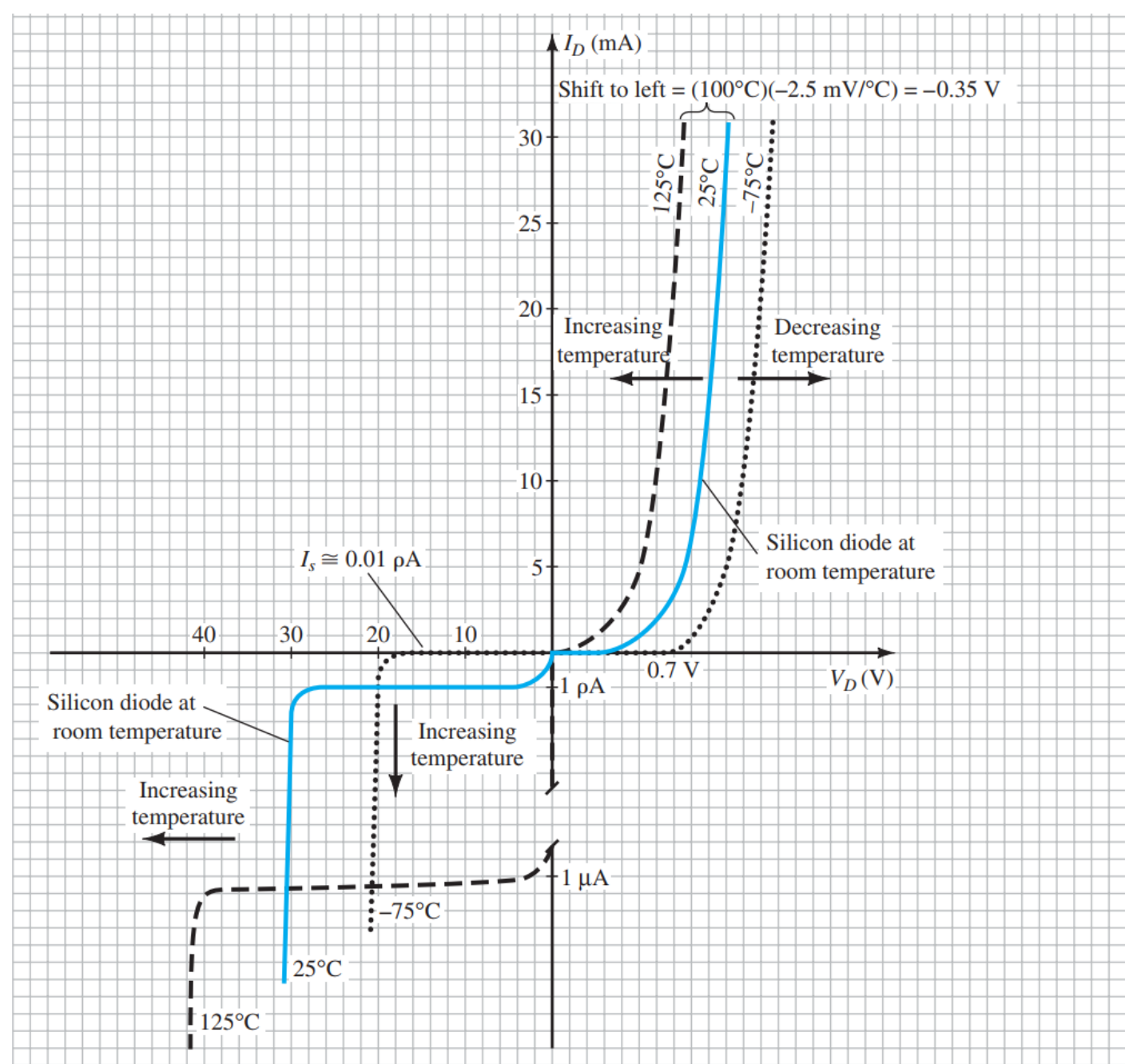

Ideal versus practical

Electronic Devices and Circuit
Theory – Boylestad, Nashelsky

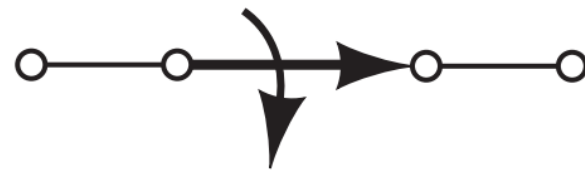
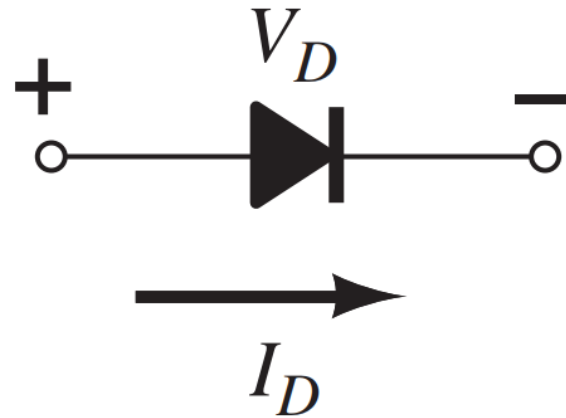

Forward-biased

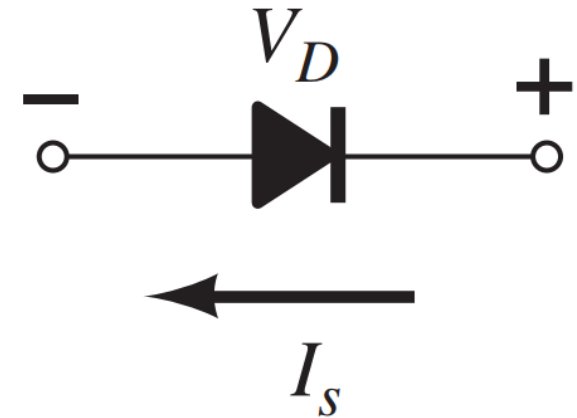

Reverse-biased

Ideal versus practical

Electronic Devices and Circuit Theory – Boylestad, Nashelsky

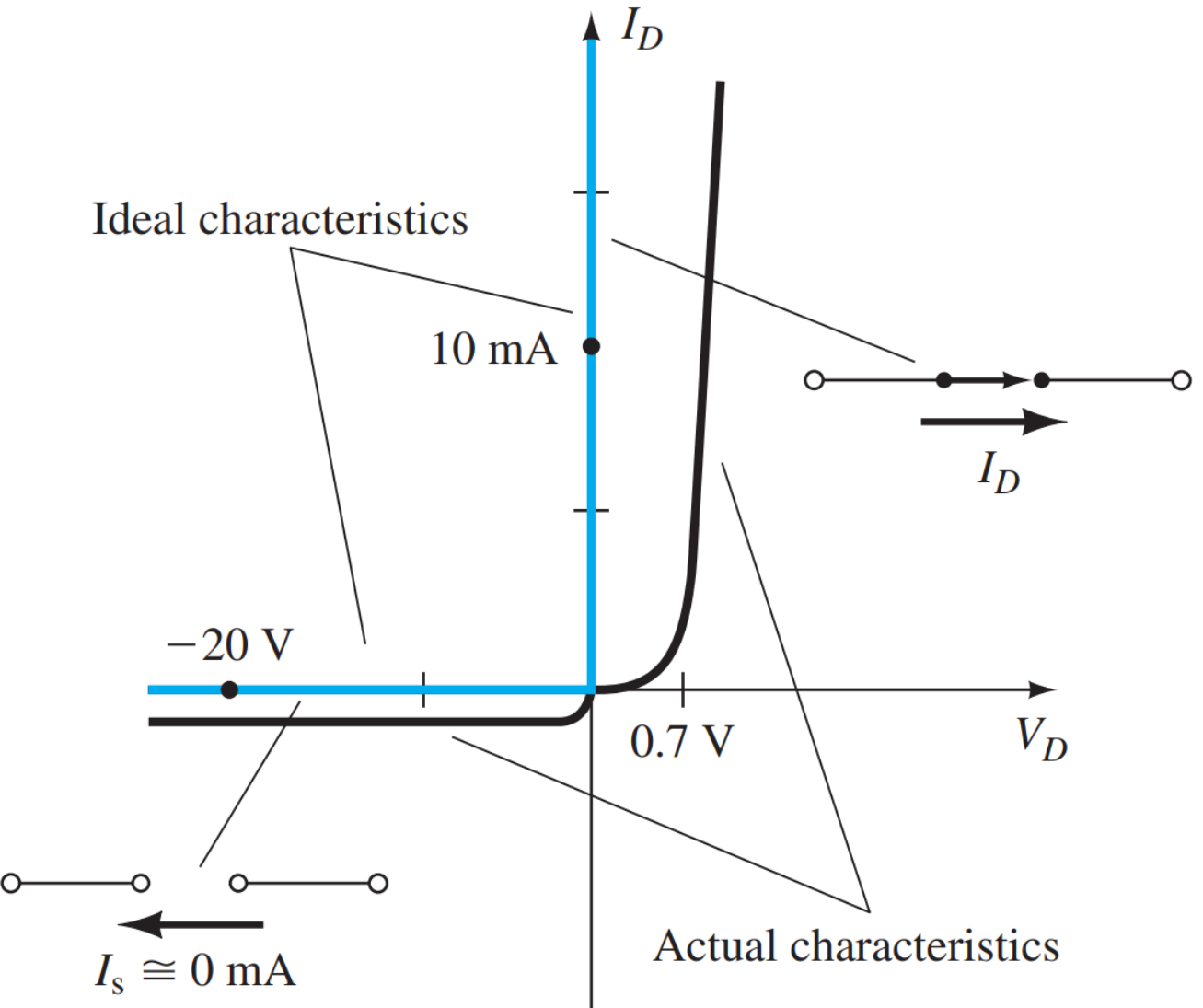

DC or Static Resistance

$$R_D = \frac{V_D}{I_D}$$

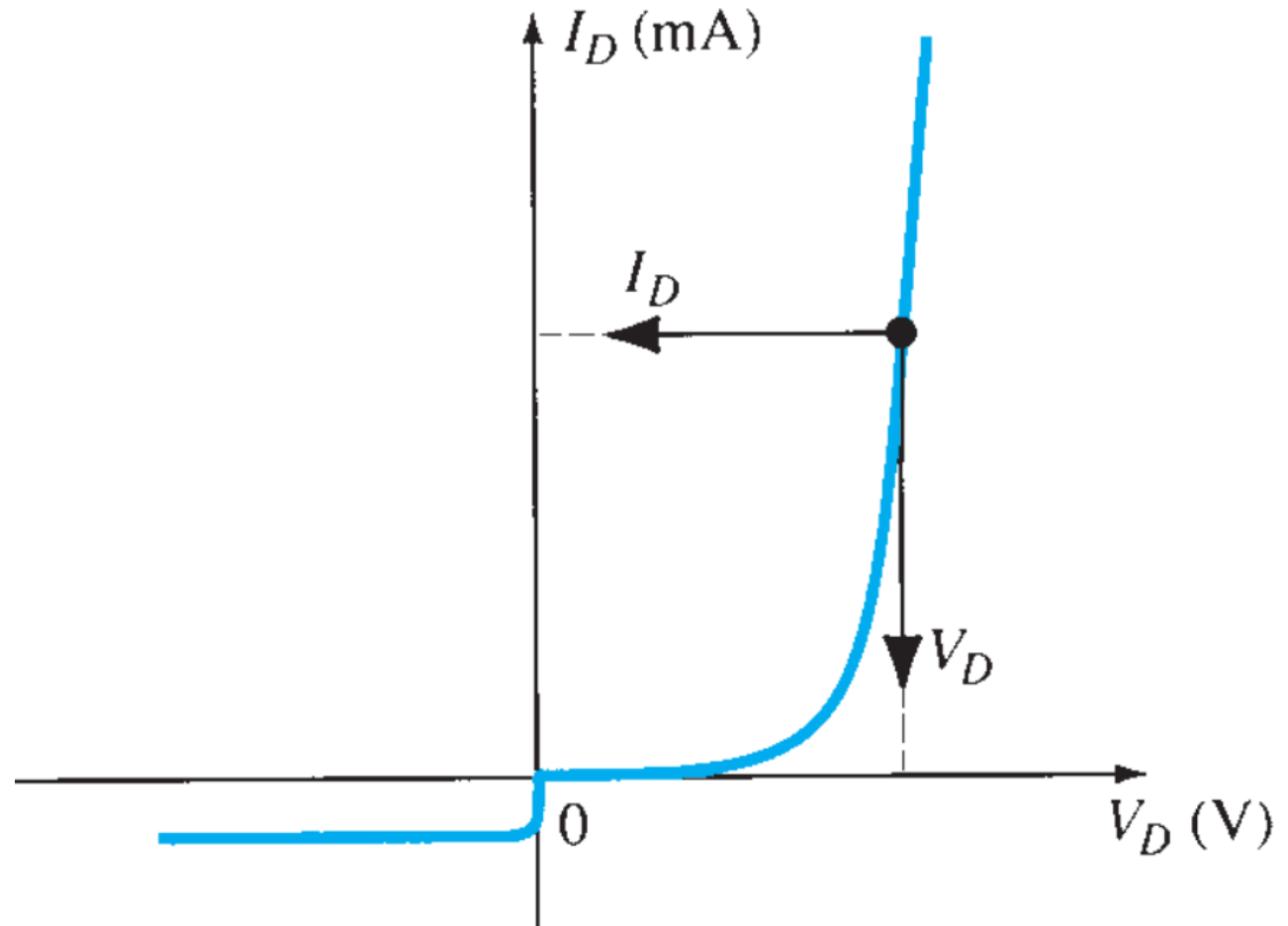

DC or Static Resistance

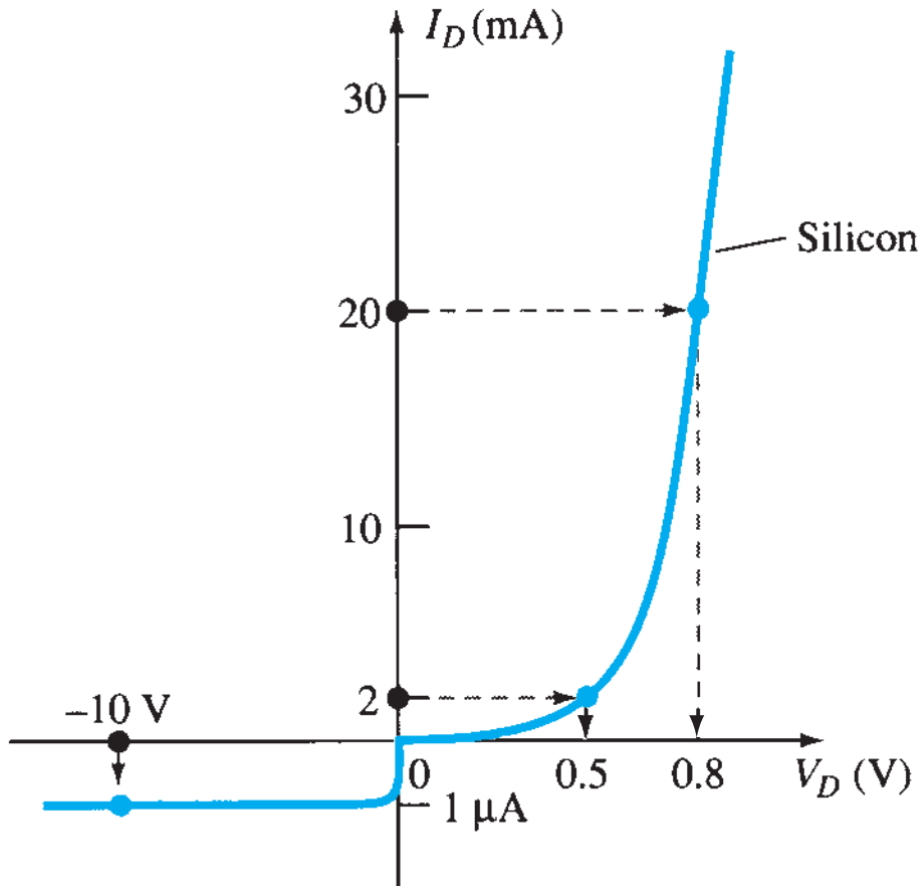

At $I_D = 2 \text{ mA}$, $V_D = 0.5 \text{ V}$ (from the curve) and

$$R_D = \frac{V_D}{I_D} = \frac{0.5 \text{ V}}{2 \text{ mA}} = \mathbf{250 \Omega}$$

At $I_D = 20 \text{ mA}$, $V_D = 0.8 \text{ V}$ (from the curve) and

$$R_D = \frac{V_D}{I_D} = \frac{0.8 \text{ V}}{20 \text{ mA}} = \mathbf{40 \Omega}$$

AC or Dynamic Resistance

$$r_d = \frac{\Delta V_d}{\Delta I_d}$$

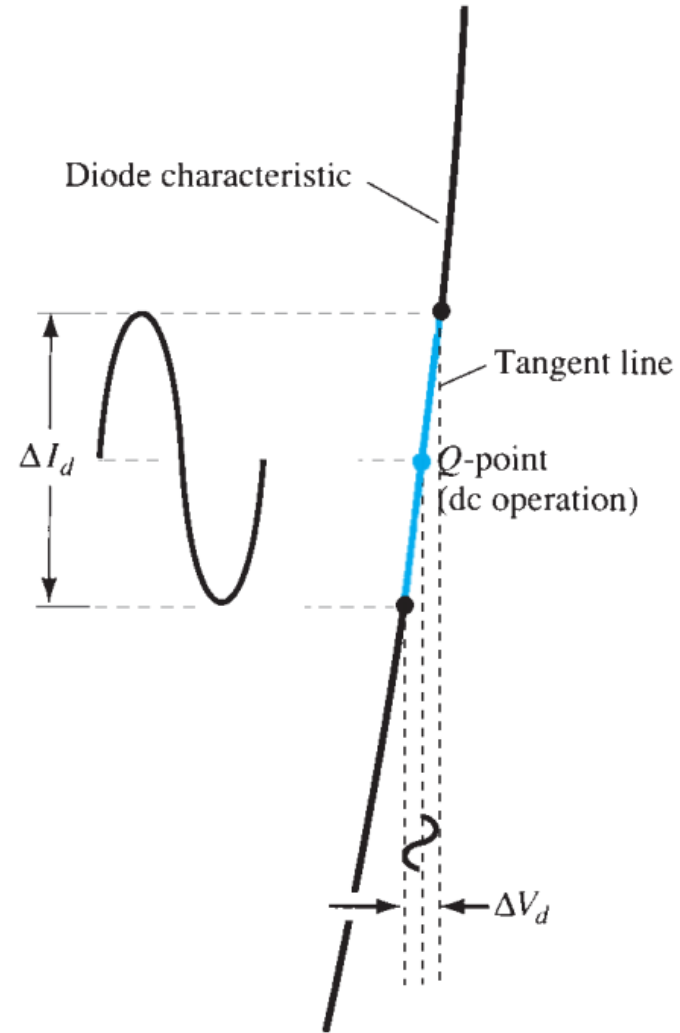

Electronic Devices and Circuit Theory – Boylestad, Nashelsky

AC or Dynamic Resistance

$$r_d = \frac{\Delta V_d}{\Delta I_d} = \frac{0.02 \text{ V}}{10 \text{ mA}} = \mathbf{2 \Omega}$$

$$r_d = \frac{\Delta V_d}{\Delta I_d} = \frac{0.11 \text{ V}}{4 \text{ mA}} = \mathbf{27.5 \Omega}$$

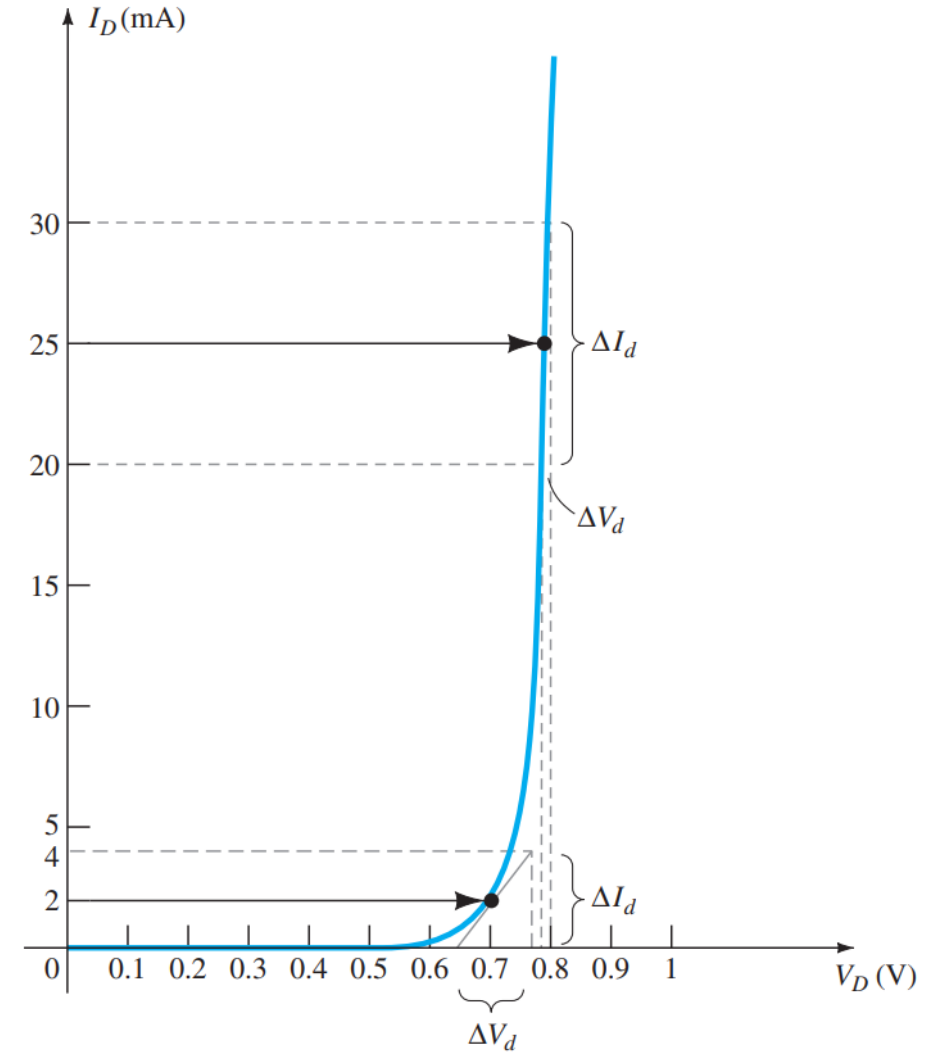

Breakdown region

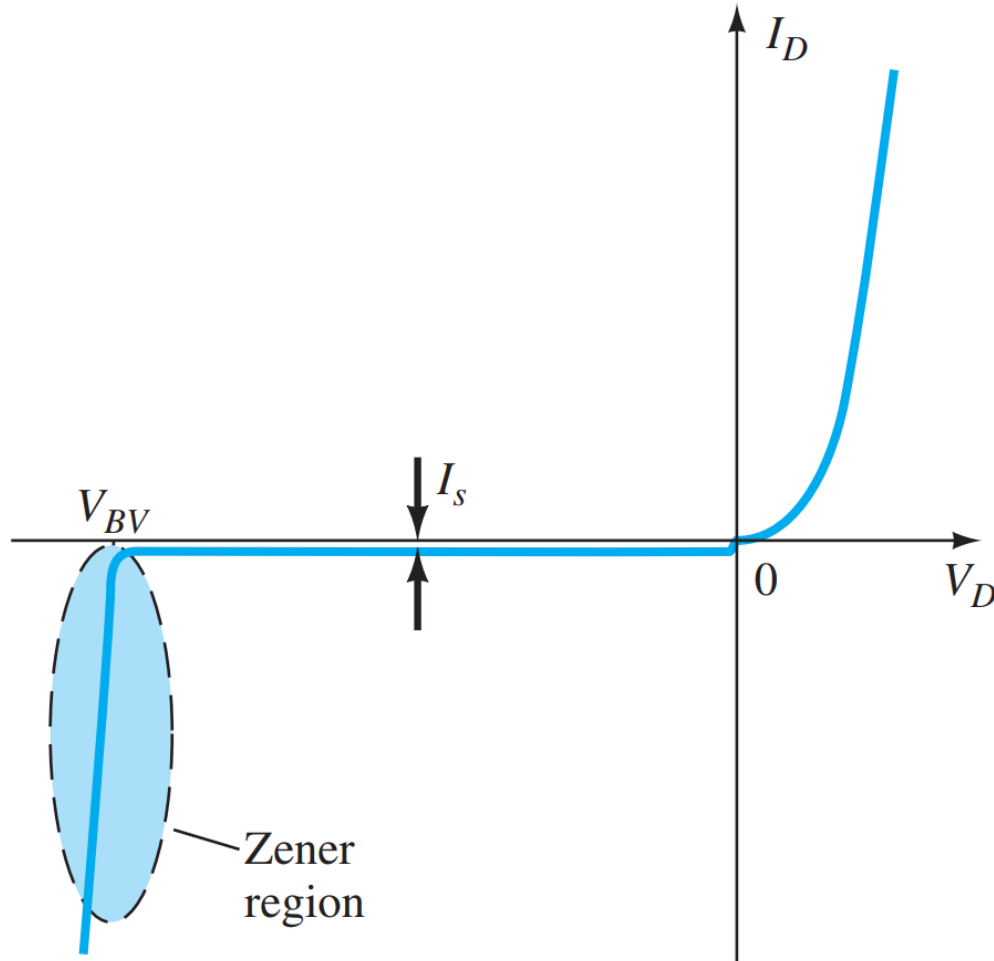

Electronic Devices and Circuit
Theory – Boylestad, Nashelsky



Breakdown region

- (1) Avalanche breakdown**, in which some of the electrons accelerated by the large reverse voltage acquire enough energy to excite electron-hole pairs, which if sufficiently energetic, go on to excite additional electron-hole pairs, and so forth.
- (2) Zener breakdown**, which is based on the observation that at very high reverse voltage the thickness (not the height) of the potential barrier between the two sides of the junction becomes so small that quantum tunneling becomes possible. At that point, the current does increase rapidly.



Zener diode

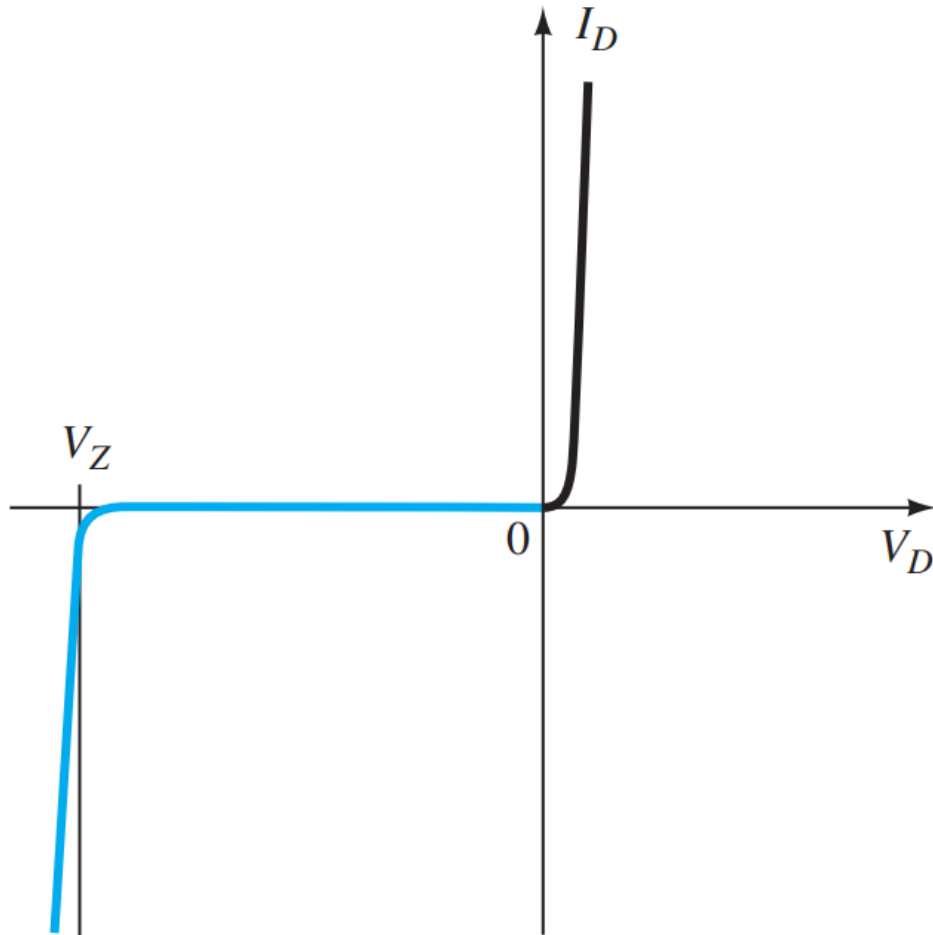

Electronic Devices and Circuit Theory – Boylestad, Nashelsky

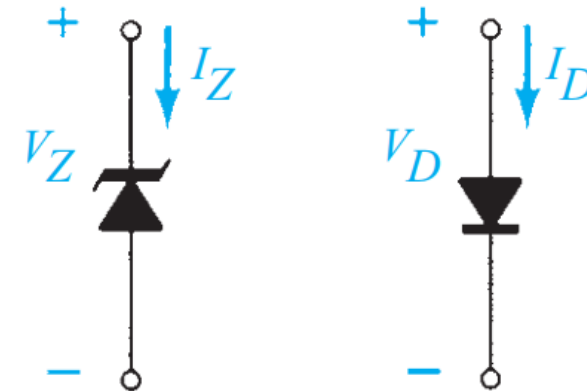

Light-Emitting Diode (LED)

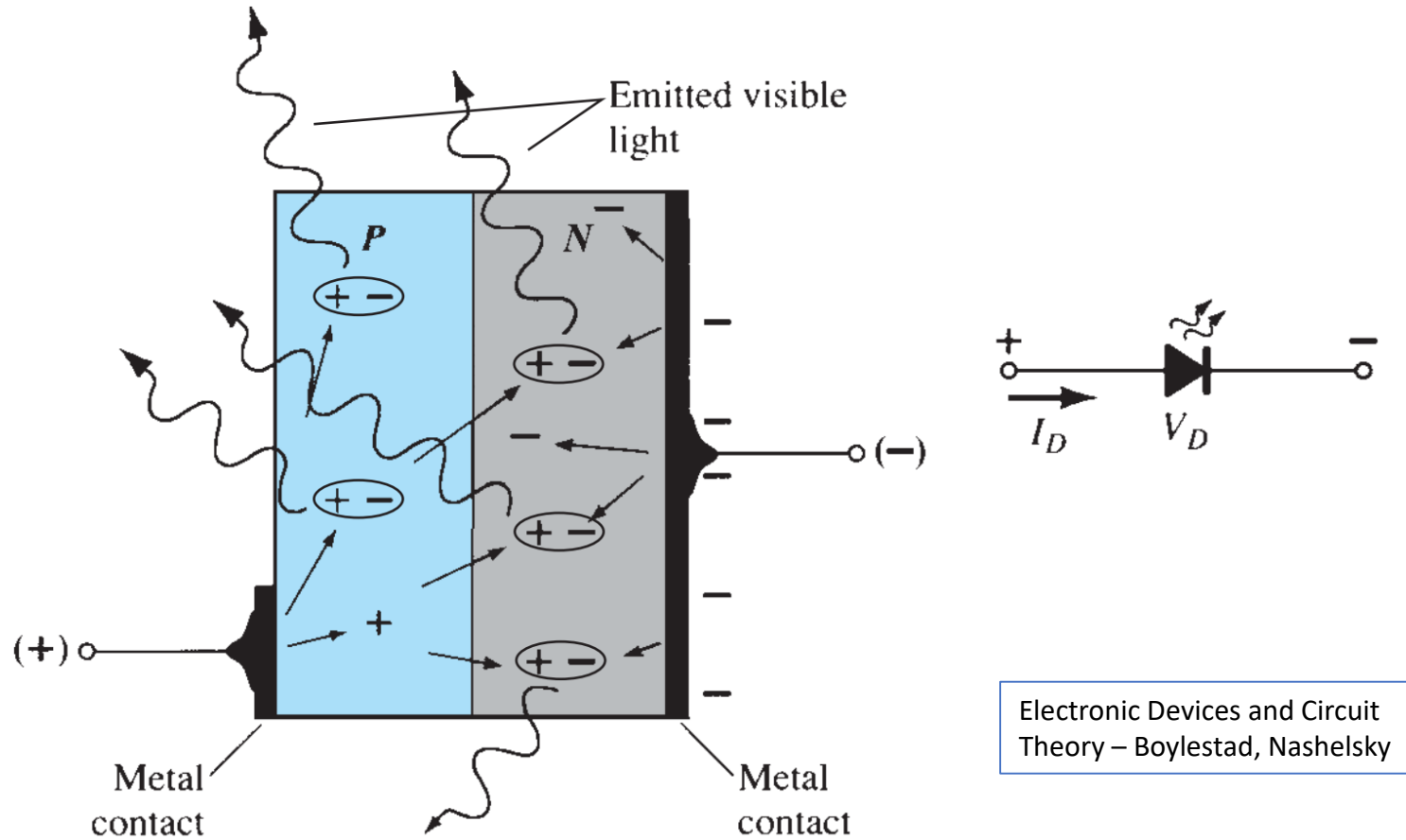

Electronic Devices and Circuit Theory – Boylestad, Nashelsky

Light-Emitting Diode (LED)

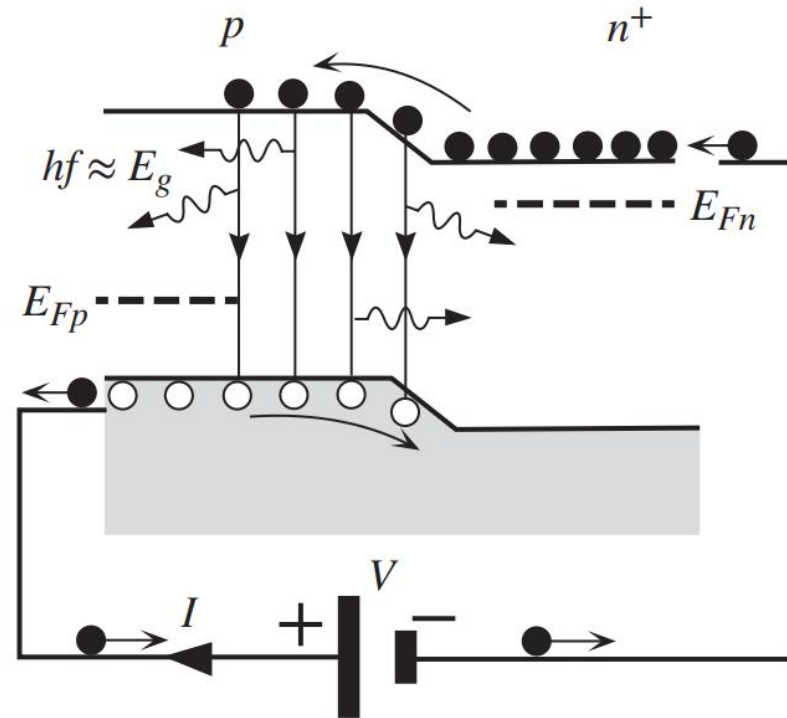
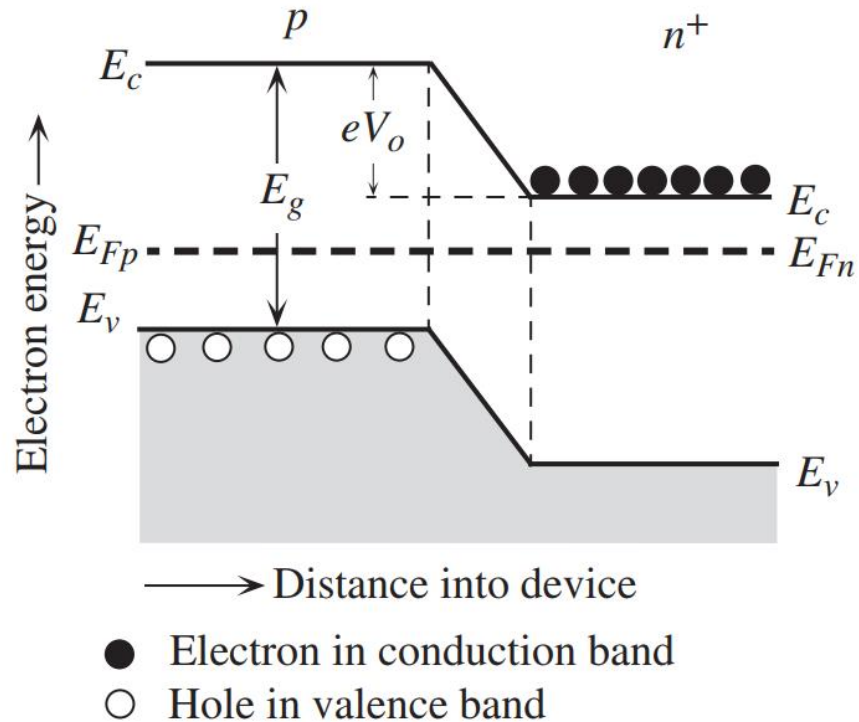

Principles of Electronic Materials and Devices – S.O. Kasap



Light-Emitting Diodes

Color	Construction	Typical Forward Voltage (V)
Amber	AlInGaP	2.1
Blue	GaN	5.0
Green	GaP	2.2
Orange	GaAsP	2.0
Red	GaAsP	1.8
White	GaN	4.1
Yellow	AlInGaP	2.1



The basic principle of operation of the solar cell

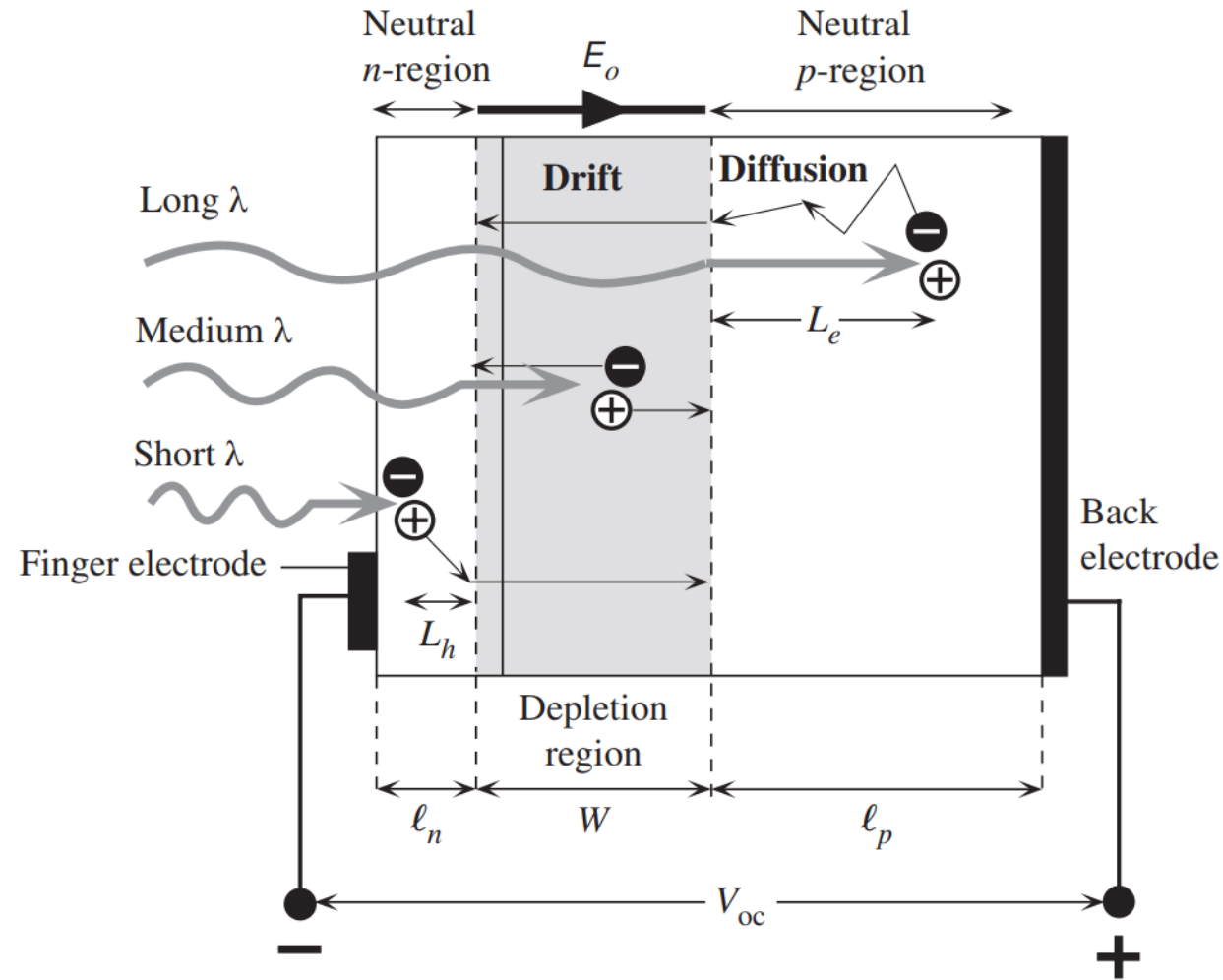

Principles of Electronic Materials and Devices – S.O. Kasap



Light-Emitting Diodes

In Si and Ge diodes the greater percentage of the energy converted during recombination at the junction is dissipated in the form of heat within the structure, and the emitted light is insignificant.

Diodes constructed of GaAs emit light in the infrared (invisible) zone during the recombination process at the p–n junction

Even though the light is not visible, infrared LEDs have numerous applications where visible light is not a desirable effect. These include security systems, industrial processing, optical coupling, safety controls such as on garage door openers, and in home entertainment centers, where the infrared light of the remote control is the controlling element.



Diode

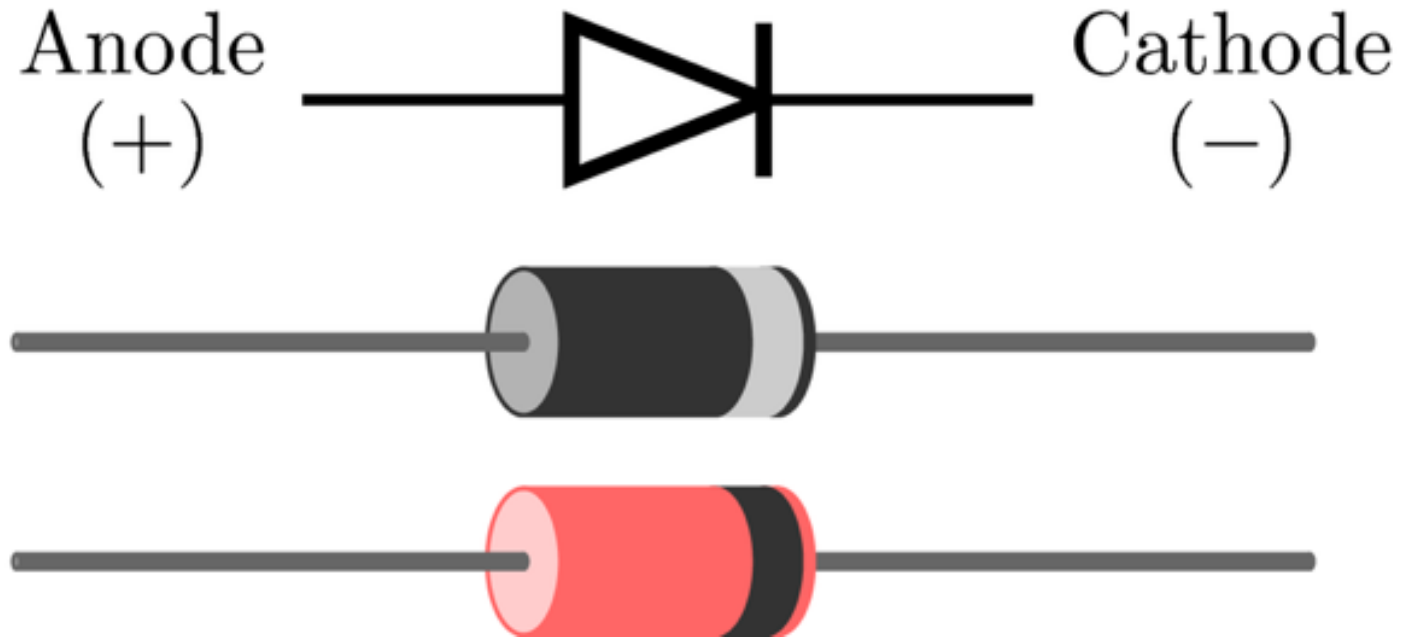

Diode polarity

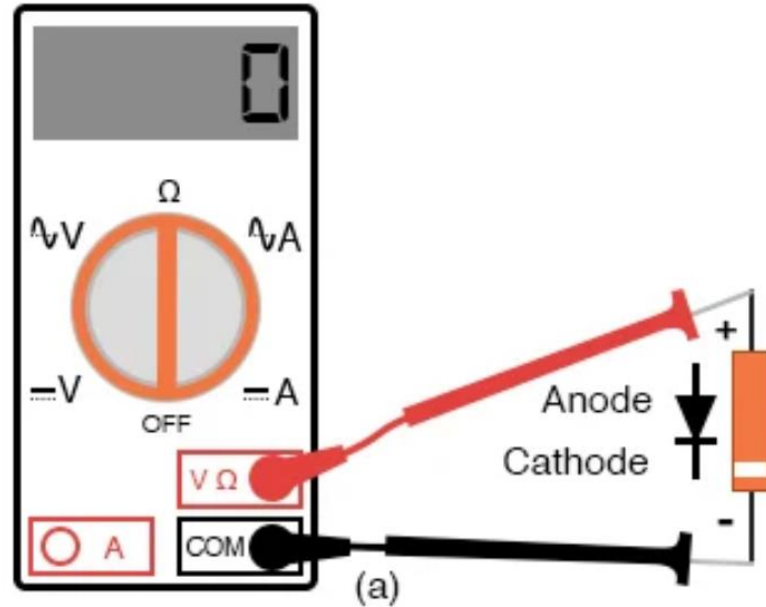

(a) Low resistance indicates forward bias, black lead is cathode and red lead anode.

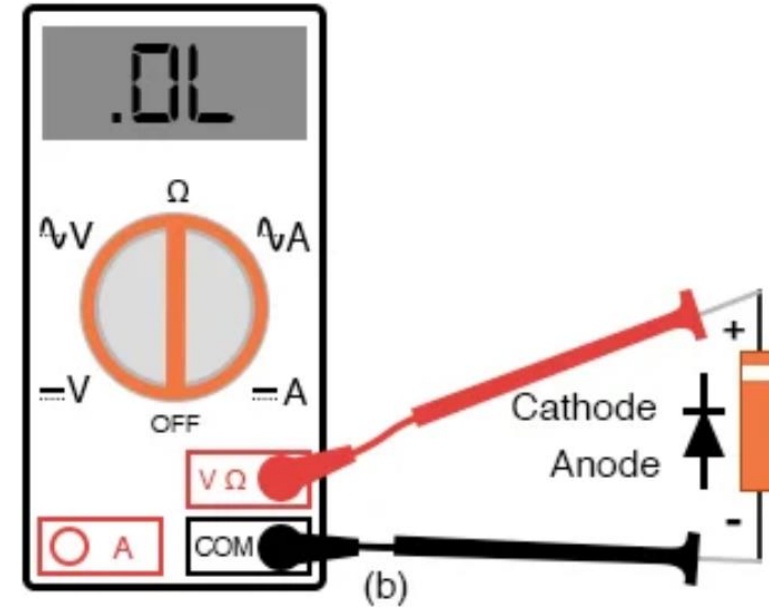

(b) Reversing leads shows high resistance indicating reverse bias.

allaboutcircuits.com

Diode polarity

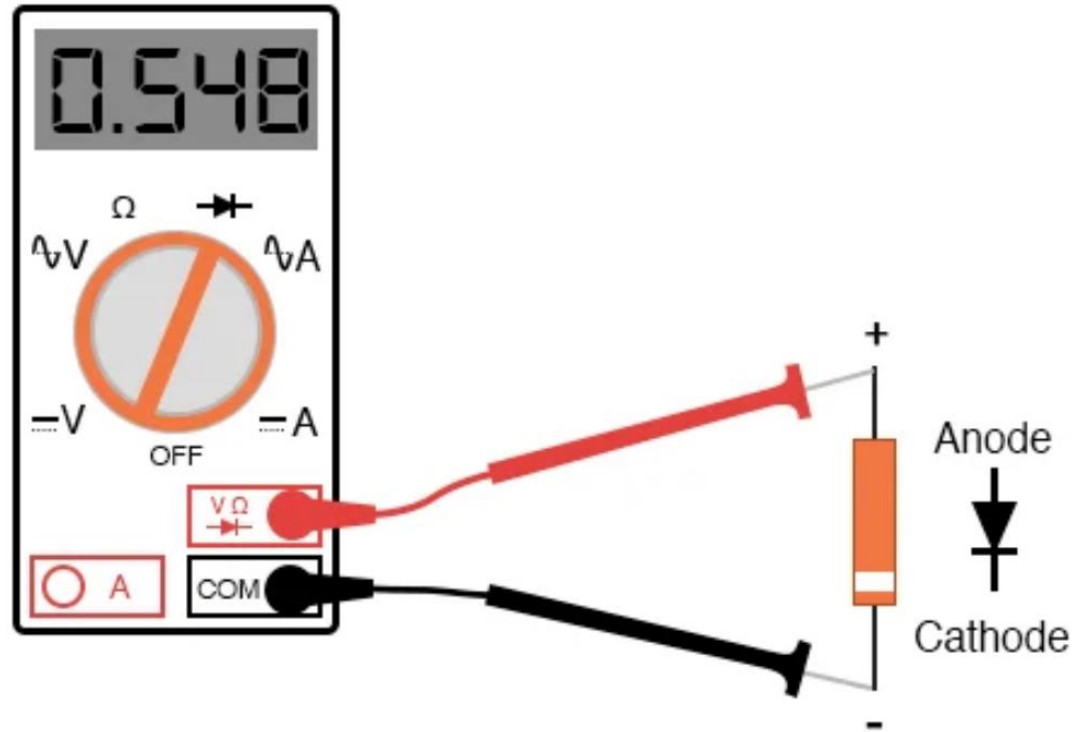

allaboutcircuits.com

Meter with a “Diode check” function

Readings

Electronic Devices and Circuit Theory
– Robert L. Boylestad and Louis Nashelsky

Chapter 1: Semiconductor Diodes

